



# Contents

TIP  
Click on "page references" in this PDF - to jump to page!

<b>Welcome .....</b>	<b>4</b>
Finger Trapping – The Problem .....	4
Product Summary .....	5
Our Approach to Testing .....	5
**At a Glance - Key Features** .....	6
<b>What's in the ALU30 Kit? .....</b>	<b>7</b>
<b>ALU30 Doorset Dimensions .....</b>	<b>8</b>
<b>FD30 Fire Performance - Lorient .....</b>	<b>9</b>
Lorient Polyproducts - FD30 Maximum Leaf Sizes .....	9
Lorient Polyproducts - ALU30 Doorset Specification .....	10
Lorient Polyproducts - ALU30 Seal Specification .....	11
<b>FD30 Fire Performance - ISL .....</b>	<b>12</b>
Intumescent Seals Ltd - FD30 Maximum Leaf Sizes .....	12
Intumescent Seals Ltd - ALU30 Doorset Specification .....	13
Intumescent Seals Ltd - ALU30 Seal Specification .....	14
<b>What's in the ALU60 Kit? .....</b>	<b>15</b>
<b>ALU60 Doorset Dimensions .....</b>	<b>16</b>
<b>FD60 Fire Performance - Lorient .....</b>	<b>17</b>
Lorient Polyproducts - FD60 Maximum Leaf Sizes .....	17
Lorient Polyproducts - ALU60 Doorset Specification .....	18
Lorient Polyproducts - ALU60 Seal Specification .....	19
<b>FD60 Fire Performance - ISL .....</b>	<b>20</b>
Intumescent Seals Ltd - FD60 Maximum Leaf Sizes .....	20
Intumescent Seals Ltd - ALU60 Doorset Specification .....	21
Intumescent Seals Ltd - ALU60 Seal Specification .....	22
<b>ALU30 Manufacturing Guidelines .....</b>	<b>24</b>
Frame Specification - Single Doors.....	24
Frame Specification - Double Doors.....	25
Lipping Specification .....	26
Rebate & Mortice Details .....	27
Floor Spring with ALU30 kits.....	28
Floor Pivot Positioning (44 mm doors) .....	29
<b>ALU30 Acoustic Seal Option Drawings.....</b>	<b>30</b>
<b>ALU60 Manufacturing Guidelines .....</b>	<b>31</b>
Frame Specification - Single Doors.....	31
Frame Specification - Double Doors.....	32
Lipping Specification .....	33
Rebate & Mortice Details .....	34
Floor Spring with ALU60 kits.....	35
Floor Pivot Positioning (54 mm doors) .....	36
<b>ALU60 Acoustic Seal Option Drawings.....</b>	<b>37</b>
<b>Shared Details: ALU30 &amp; ALU60 .....</b>	<b>38</b>
Fitting Components .....	38
Undercuts & Floor Pivot Adjustment.....	39
Sizing Door Stops to Perfection.....	40
Opening Angle Limit .....	41
Installation Instructions .....	42
Ordering Safehinge ALU Kits .....	43



**Use of Technical and Manufacturing Guidelines**

These guidelines are for use only by parties expressly and directly authorised by Safehinge Limited or its authorised distributors to (a) evaluate the doorset for potential use and/or manufacture and/or (b) manufacture and maintain the doorset. No other use or disclosure of the guidelines is permitted.

**Copyright and Patent**

No part of this publication may be reproduced or edited in any form or by any means whether electronic, mechanical, photocopying, recording or otherwise, without Safehinge Limited's prior written permission. This document and all other documentation supplied by or on behalf of Safehinge Ltd are also copyright Safehinge Ltd – all rights are reserved.

The Safehinge doorset is protected by intellectual property rights and is patent protected.

**Disclaimer**

Other than death or personal injury caused by negligence and other liabilities which may not be excluded or limited by law, Safehinge Ltd excludes any and all liability for (a) failure to follow the guidelines or other technical documentation in any manner; and/or (b) defective or inaccurate manufacture, installation and/or maintenance of the doorset and/or any of its components.



safehinge

## Welcome

Welcome to the Safehinge ALU  
Technical and Manufacturing Guidelines.

We hope you will find these guidelines easy to use and helpful. This document is laid out as follows:

### Technical Manual

- i) ALU30 (44 mm) product
- ii) ALU60 (54 mm) product

This section focuses on the performance capabilities of the Safehinge ALU range in fire, acoustic and mechanical disciplines. As a specifier you'll find out what you can achieve with ALU and how to do it.

### Manufacturing Guidelines

- i) ALU30 (44 mm) product
- ii) ALU60 (54 mm) product

These sections focus on manufacturing details including doorset sections, mortices and component installation instructions. A must read to ensure compliance.

### Common installation features

## Finger Trapping – The Problem

The Royal Society for the Prevention of Accidents (RoSPA) estimates that **30,000 children trap and seriously injure their fingers in doors every year** and more than 1,500 of these will need surgery. **Adults too** - particularly those with special needs, physical or mental impairments and the elderly - **are susceptible to finger entrapment.**

The estimated **cost of these injuries to the National Health Service is £200 million** per annum.

Further research carried out at the Royal Sick Children's Hospital in Glasgow highlighted the severity of the injuries which occur. In six months, 136 children were admitted to A&E after trapping their fingers in a door with 45% suffering bone/joint injuries and 11% amputation. The cost of litigation for these injuries can be substantial. The responsibility for reducing these injuries falls to building owners and specifiers.

Safehinge ALU eliminates any opportunity for finger trappings to occur. Clever design means there is no opportunity for wandering fingers to be trapped, which is without doubt **the best way to protect against accidents: total prevention.**



## Product Summary

Integrated finger protection kit incorporating specialised pivot set, aluminium edge profile and intumescent.

### Suitable for door type

Single and double leaf; single and double swing  
44 mm and 54 mm door thickness (primary test evidence generated using Halspan / Blankfort core)

### Fire/smoke

FD30, FD30 (S), FD60, FD60 (S) rating

### Mechanical

Maximum recommended load: 120 kg  
Severe Duty rating (DD171)  
Tested to 1.5 million cycles

### Acoustic

Rw rating up to 38 dB maximum (glazed)

### Finishes (aluminium edge profile)

Standard - natural anodised finish.  
To your request: powder coat (any RAL colour), metallic plating or colour anodising.

### Standard lengths

2.1 m and 2.4 m standard supply lengths.

## Our Approach to Testing

**At Safehinge we invest significantly into R&D so you don't have to.** Our focus is on three central disciplines: **fire, mechanical and acoustic testing.**

The Safehinge ALU has been **rigorously tested as part of an integrated doorset**, as opposed to individual components. Integrated testing is recognised as more onerous as it tests the product as part of an overall assembly (replicating real-life scenarios more closely), rather than artificially isolating components. Successful outcomes from such testing provide the specifier with **total confidence that the product is truly fit for purpose.**



Our approach to testing is simple - we selected widely used, commercially available (door core, intumescent and door frame) materials to test with to give our customers as many options as possible. You'll see which materials we've got coverage for in this manual. If you follow the guidelines given, you can **rest assured your product will comply with the performance levels detailed.** If you don't see the materials you wish to use listed, please contact us to let us know.



## **\*\* At a Glance - Key Features \*\***

Whilst we strongly recommend reading this document in full, here are some key points when specifying / working with Safehinge ALU:

### **\*\* Opening angle - limit to 100° \*\***

You must restrict the opening angle of Safehinge ALU doors to 100° - 110° maximum. See page 41.

### **\*\* Floor plate or L-bracket \*\***

Which bottom pivot best suits your project?  
See page 29 (ALU30) or page 36 (ALU60).

### **\*\* Underfloor heating - plan ahead \*\***

Whether using floor plate or L-bracket, we always recommend supporting and fixing the bottom pivot firmly to the floor. This should be accounted for at design stage, page 29 (ALU30) and page 36 (ALU60).

### **\*\* Clearance underneath door - plan ahead \*\***

Do you need a standard or long stem bearing to achieve your desired clearance under the door? See "Undercuts & Floor Pivot Adjustment" on page 39.

### **\*\* Door stops - need to be accurate \*\***

The finger safety function of Safehinge ALU doorsets

means a bit of attention to detail is required when it comes to the door stops. See page 40.

### **\*\* Are you using cores, frame materials & intumescent consistent with Safehinge test evidence? \*\***

Safehinge test evidence was primarily generated with Halspan/Blankfort cores and Lorient/ISL intumescent seals. Full details contained within Technical Manual.

### **\*\* Frame head - size \*\***

Safehinge ALU requires a pivot mechanism to be machined into the frame head. This results in a frame head that is thicker than typical doorsets. See page 24 onwards for details.

### **\*\* Concentric \*\***

The pivot centre on the door and the rounded aluminium edge profile must always be concentric. Follow mortice / rebate details on page 27 (ALU30) and page 34 (ALU60) to ensure this.

### **\*\* Particleboard core \*\***

If you are planning to use particleboard core, please also ensure you use a T-section lipping to ensure mechanical stability and a firm fixing for the pivot straps. See page 26 (ALU30) and page 33 (ALU60).

# What's in the ALU30 Kit?

Product components explained.

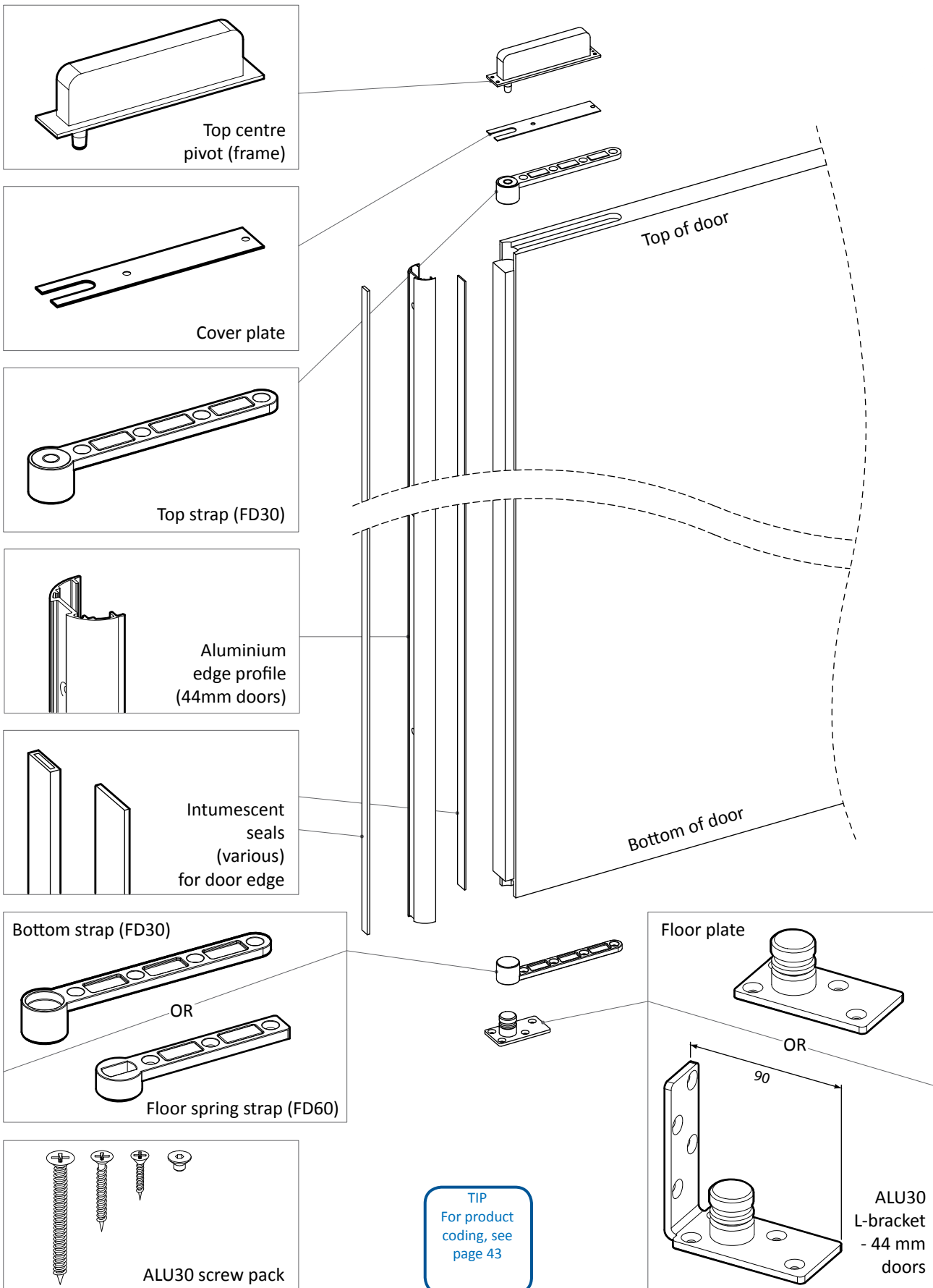

# ALU30 Doorset Dimensions

The guide below will help you work out the overall doorset dimensions using the frame width, clear opening width or preferred door leaf dimension as the starting point.

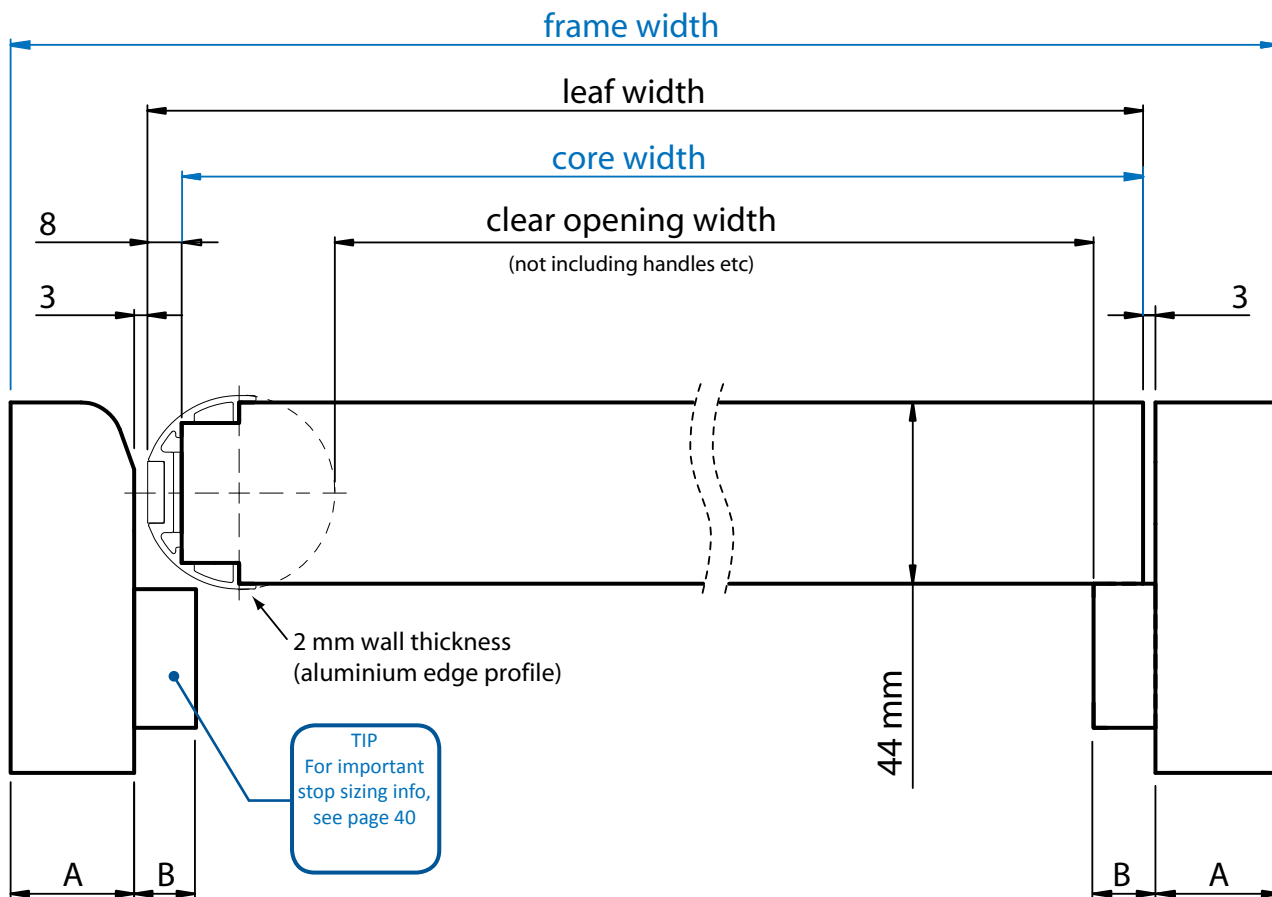

## **Frame width ↔ Clear opening width:**

$$\text{Clear opening width} = \text{Frame width} - 2A - B - 49$$

$$\text{Frame width} = \text{Clear opening width} + 2A + B + 49$$

EXAMPLE:

$$\text{Clear opening width} = 992 \text{ mm} - (2 \times 30 \text{ mm}) - 15 \text{ mm} - 49 \text{ mm} = 868 \text{ mm}$$

## **Clear opening width ↔ Leaf width:**

$$\text{Leaf width} = \text{Clear opening width} + B + 43$$

$$\text{Clear opening width} = \text{Leaf width} - B - 43$$

EXAMPLE:

$$\text{Leaf width} = 868 \text{ mm} + 15 \text{ mm} + 43 \text{ mm} = 926 \text{ mm}$$

## **Frame width ↔ Leaf width:**

$$\text{Leaf width} = \text{Frame width} - 2A - 6$$

$$\text{Frame width} = \text{Leaf width} + 2A + 6$$

EXAMPLE:

$$\text{Leaf width} = 992 \text{ mm} - (2 \times 30 \text{ mm}) - 6 \text{ mm} = 926 \text{ mm}$$

## **Leaf width ↔ Lipped core width:**

$$\text{Lipped core width} = \text{Leaf width} - 8 \text{ mm}$$

$$\text{Leaf width} = \text{Lipped core width} + 8 \text{ mm}$$

EXAMPLE:

$$\text{Lipped core width} = 926 \text{ mm} - 8 \text{ mm} = 918 \text{ mm}$$

# FD30 Fire Performance - Lorient



## Lorient Polyproducts - FD30 Maximum Leaf Sizes

Global Assessment Chilt/A10206 permits expansion of leaf sizes, alternative frame materials, glazing, door face finishes and various ancillaries, as summarised below. Please enquire if the information you require is not presented here.

### Latched, single acting, single leaf



	S1	S2
<b>W</b>	920	1105
<b>H</b>	2517	2100

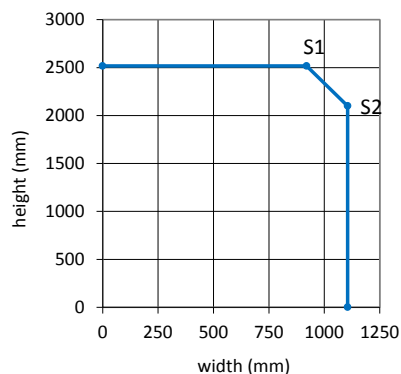

### Unlatched, single or double acting, single leaf



	S1	S2
<b>W</b>	920	1080
<b>H</b>	2467	2100

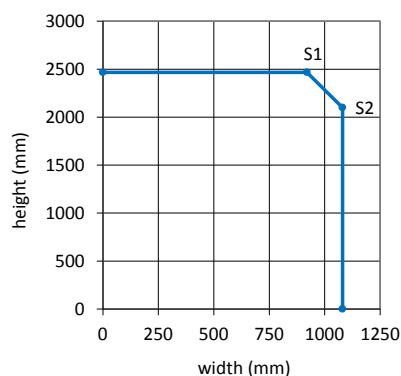

### Latched, single acting, double leaf



For unequal, double leaf – see “Unequal Double Leaf - Width Restrictions” on page 10.

	S1	S2
<b>W</b>	908	1051
<b>H</b>	2423	2100

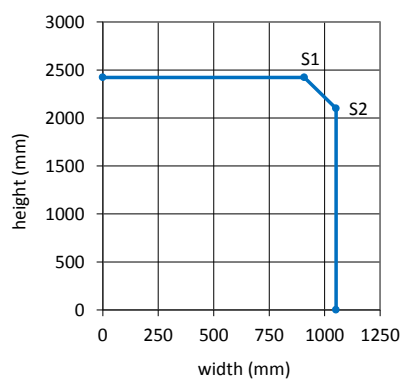

### Unlatched, single or double acting, double leaf



For unequal, double leaf – see “Unequal Double Leaf - Width Restrictions” on page 10.

	S1	S2
<b>W</b>	908	1026
<b>H</b>	2373	2100

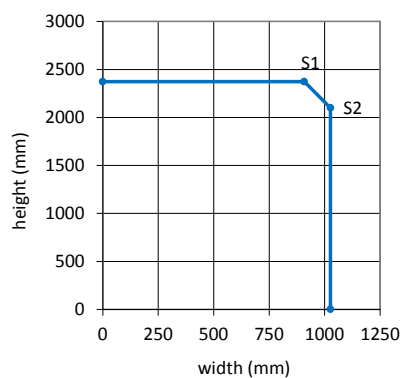

### Unequal Double Leaf - Width Restrictions

Unequal leaf double doorsets are permitted with no restriction on the smaller leaf dimension, other than it must be within the maximum size envelope given in "Lorient Polyproducts - FD30 Maximum Leaf Sizes" on page 9.

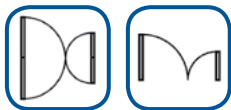

### Frame

Softwood or hardwood minimum density 510 kg/m<sup>3</sup>;  
MDF minimum density 700 kg/m<sup>3</sup>  
Minimum sections excluding stops: 90 x 48 mm (head);  
90 x 30 mm (jambs)  
Head/jamb joint: mortice & tenon or half-lapped joint with head twice screwed to jambs; mitred joint glued with non-thermally softening adhesive (e.g. PU, UF, PVA) and twice screwed, or horizontal butt joint screwed with two screw fixings. No gaps.

### Stops

Machined from solid; pinned and glued, or pinned only.

### Recommended DD171 Severe Duty Frame

Minimum sections excluding stops: 90 x 48 (head); 90 x 30 (jambs). MDF or hardwood.  
Head/jamb joint: butt jointed. Head to jambs fixed 3No. 3.5 mm x 100 mm screws per joint & PU glue.  
Stops: 35x15 mm stops pinned at 200 mm centres with 40 mm pins, or integral.

### Door blank

Halspan (44 mm)  
Blankfort 30 (45 mm)  
Others cores permitted\* – contact Lorient Polyproducts (<http://www.lorientuk.com/>) for details.

\*currently Safehinge acoustic/mechanical testing conducted with Halspan / Blankfort cores only. If an alternative door core is used, Safehinge is unable to offer primary evidence to support acoustic/mechanical performance; this provision therefore becomes the responsibility of the specifier.

### Lipping

Hardwood minimum density 640 kg/m<sup>3</sup>  
T-section lipping recommended - Halspan. Flat section - Blankfort (details - "Lipping Specification" on page 26).

### Gluelines

PU, UF, PVA, PF

### Intumescent/smoke seal

Frame seals (to be procured by door manufacturer):  
Refer to "Table 1" and "Table 2" on page 11.

Door edge seals (supplied by Safehinge):  
15x4 PVC-cased Type 617 (white) & 19x2 GPF graphite strip

Ironmongery intumescent (supplied by Safehinge):  
Graphite or Lorient M.A.P gasket wrap and pockets (for top centre pivot & top strap)

### Finishes

Timber veneers, paint finish, plastic/PVC laminate (maximum 2 mm thickness)

### Glazing

Doors fitted with Safehinge ALU30™ may be glazed subject to the fire resistance performance data available for the particular design.

# Lorient Polyproducts - ALU30 Seal Specification



## Single Door (Single/Double Acting)



		Seal Position (see "Frame Specification - Single Doors" on page 24)				
		Frame head	Hanging jamb	Closing Jamb	Threshold	R <sub>w</sub> Rating (dB)***
		A	B	C		
Rating	<b>Fire, smoke &amp; acoustic</b> (single acting only)	15x4 LP1504DS Type 617	Same as A	Same as A	Options: 1) 2x Lorient IS1511* 2) 1x Lorient IS1511* 3) Lorient IS8091si or IS8035si* 4) Lorient IS3080si or IS3081si*	32dB 31dB 32dB 31dB
	"	15x4 LP1504 Type 617 & IS1212 (Option 6)*	15x4 LP1504DS Type 617	Same as A	"	"
	<b>Fire &amp; smoke</b>	15x4 LP1504DS Type 617**	Same as A	Same as A	Refer BS9999:2008 (33.1.7)	N/A
	<b>Fire only</b>	15x4 LP1504 Type 617	Same as A	Same as A	N/A	N/A

Table 1

## Double Doors (Single/Double Acting)



		Seal Position (see "Frame Specification - Double Doors" on page 25)				
		Frame head	Hanging jamb	Meeting edge	Threshold	
		A	B	D	E	
Rating	<b>Fire &amp; smoke</b>	20x4 LP2004DS Type 617**	15x4 LP1504DS Type 617	10x4 LP1004DS Type 617	Same as D	Refer BS9999:2008 (33.1.7)
	<b>Fire only</b>	20x4 LP2004 Type 617	15x4 LP1504 Type 617	10x4 LP1004 Type 617	Same as D	N/A

Table 2

\* Details: "ALU30 Acoustic Seal Option Drawings" on page 30.

\*\* For double swing doors, IS1511 recommended (to door head) to bridge interruption in frame head seal. For example, see "Frame Head" on page 37, "point i" only.

\*\*\* R<sub>w</sub> Ratings indicated in the table above are based on Blankfort 30 core. If Halspan core is used in lieu of Blankfort, a reduction of 1dB can be expected to the R<sub>w</sub> Rating, e.g. Blankfort 30 R<sub>w</sub> Rating fully caulked = 34dB; Halspan (44 mm) R<sub>w</sub> Rating fully caulked = 33dB.

# FD30 Fire Performance - ISL



## Intumescent Seals Ltd - FD30 Maximum Leaf Sizes

Field of Application Report IFCA/08160 permits expansion of leaf sizes and other details, as summarised below. Leaf sizes are affected by intumescent specification. Two options are available: Standard & Enhanced (details page 14).

### Latched, single acting, single leaf



	S1	S2	E1	E2
<b>W</b>	770	1022	826	1097
<b>H</b>	2550	2045	2738	2195

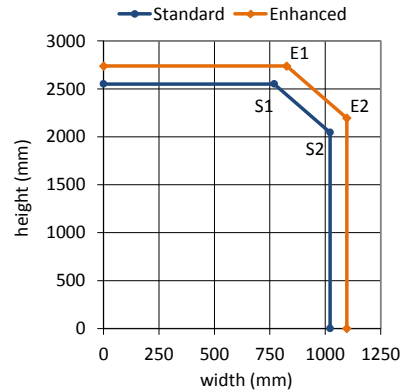

### Unlatched, single or double acting, single leaf

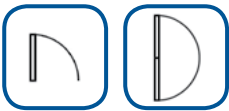

	S1	S2	E1	E2
<b>W</b>	755	1003	810	1076
<b>H</b>	2501	2006	2684	2153

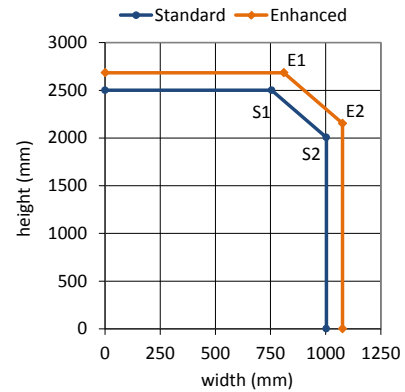

### Latched, single acting, double leaf



For unequal, double leaf – width restrictions apply.

See “Unequal Double Leaf - Width Restrictions” on page 13.

	S1	S2
<b>W</b>	878	1040
<b>H</b>	2469	2145

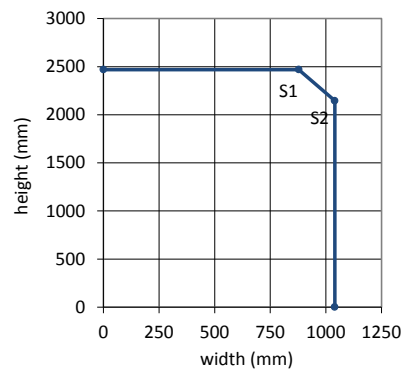

### Unlatched, single or double acting, double leaf

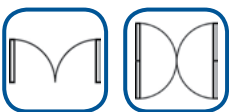

For unequal, double leaf – width restrictions apply.

See “Unequal Double Leaf - Width Restrictions” on page 13.

	S1	S2
<b>W</b>	869	1030
<b>H</b>	2445	2123

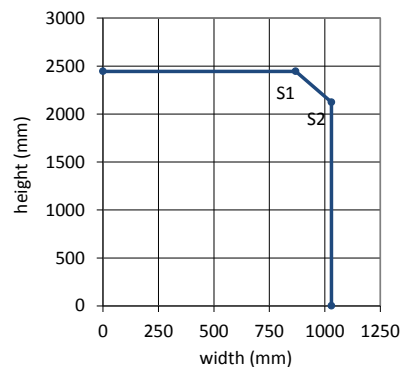

# Intumescent Seals Ltd - ALU30 Doorset Specification



## Unequal Double Leaf - Width Restrictions

In double leaf assemblies (single or double acting) each leaf is permitted to be of the same width, up to the maximum width given in

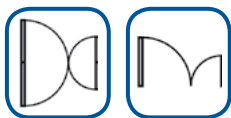

“Intumescent Seals Ltd - FD30 Maximum Leaf Sizes” on page 12.

If leaves are both unlatched/unbolted and of unequal width, the small leaf must be no more than 550 mm narrower than the large leaf. This is to reduce the level of differential deflection in fire. If the smaller leaf is bolted, then there is no limit on the ratio of leaf widths, although the large leaf must still be within the maximum size envelope.

In all instances, the width of the small leaf must not be less than 300 mm wide.

## Frame

Softwood or hardwood minimum density 510 kg/m<sup>3</sup>;

MDF minimum density 700 kg/m<sup>3</sup>

Minimum sections excluding stops: 75 x 48 mm (head);

75 x 30 mm (jambs)

Head/jamb joint: mortice & tenon or half-lapped joint with head twice screwed to jambs; mitred joint glued with non-thermally softening adhesive (e.g. PU, UF, PVA) and twice screwed, or horizontal butt joint screwed with three screw fixings.

## Stops

Machined from solid; pinned and glued, or pinned only.

## Recommended DD171 Severe Duty Frame

Minimum sections excluding stops: 90 x 48 (head); 90 x 30 (jambs). MDF or hardwood.

Head/jamb joint: butt jointed. Head to jambs fixed 3No. 3.5 mm x 100 mm screws per joint & PU glue.

Stops: 35x15 mm stops pinned at 200 mm centres with 40 mm pins, or integral.

## Door blank

Halspan (44 mm)

Blankfort 30 (45 mm)

## Lipping

Hardwood minimum density 640 kg/m<sup>3</sup>

T-section lipping recommended - Halspan. Flat section - Blankfort (details - “Lipping Specification” on page 26)

## Gluelines

PU, UF, melamine-UF, cross-linked PVA, PVA, PF

## Intumescent/smoke seal

Frame seals (to be procured by door manufacturer):

Refer to “Table 3” and “Table 4” on page 14.

Door edge seals (supplied by Safehinge):

15x4 PVC-cased Therm-a-seal (white) & 19x2 plain intumescent strip

Ironmongery intumescent (supplied by Safehinge):

Graphite gasket wrap and pockets (for top centre pivot & top strap)

## Finishes

Timber veneers, paint finish, plastic/PVC laminate (maximum 2 mm thickness)

## Glazing

Maximum area of apertures: 0.39m<sup>2</sup>

Maximum vertical length of aperture: 1540 mm

Maximum horizontal length of aperture: 300 mm

Minimum distance from leaf edge (sides): 100 mm

Minimum distance from bottom of leaf: 200 mm

More than one aperture may be included in each leaf subject to the above limitations. The minimum distance between apertures is 100 mm. Aperture shape is not restricted provided the glazing system and beads are compatible with that shape.

A wide range of glazing systems are permitted. Please contact Technical Support for details.

# Intumescent Seals Ltd - ALU30 Seal Specification



## Single Door (Single/Double Acting)

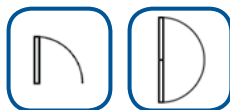

		Seal Position (see "Frame Specification - Single Doors" on page 24)				R <sub>w</sub> Rating (dB) <sup>***</sup>
		Frame head	Hanging jamb	Closing Jamb	Threshold	
		A	B	C		
Rating	<b>Fire, smoke &amp; acoustic</b> (single acting only)	"Standard" 15x4 "Enhanced" 20x4 ISL Therm-a-blade	15x4 Therm-a-blade	Same as B	Options: 1) 2x Lorient IS1511* 2) 1x Lorient IS1511* 3) Lorient IS8091si or IS8035si* 4) Lorient IS3080si or IS3081si* 5) Norsound NOR855*	32dB 31dB 32dB 31dB 31dB
	"	"Standard" 15x4 "Enhanced" 20x4 ISL Therm-a-seal & NOR710 (Option 7)*	15x4 Therm-a-blade	15x4 Therm-a-seal & NOR710 (Option 7)*	"	"
	<b>Fire &amp; smoke</b>	"Standard" 15x4** "Enhanced" 20x4 ISL Therm-a-blade**	15x4 Therm-a-blade	Same as B	Refer BS9999:2008 (33.1.7)	N/A
	<b>Fire only</b>	"Standard" 15x4 "Enhanced" 20x4 ISL Therm-a-seal	15x4 Therm-a-seal	Same as B	N/A	N/A

Table 3

## Double Doors (Single/Double Acting)

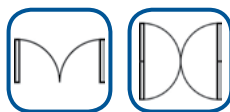

		Seal Position (see "Frame Specification - Double Doors" on page 25)				Threshold
		Frame head	Hanging jamb	Meeting edge		
		A	B	D	E	
Rating	<b>Fire &amp; smoke</b>	20x4 Therm-a-blade**	15x4 Therm-a-blade	10x4 Therm-a-blade	Same as D	Refer BS9999:2008 (33.1.7)
	<b>Fire only</b>	20x4 Therm-a-seal	15x4 Therm-a-seal	10x4 Therm-a-seal	Same as D	N/A

Table 4

\* Details: "ALU30 Acoustic Seal Option Drawings" on page 30.

\*\* For double swing doors, IS1511 recommended (to door head) to bridge interruption in frame head seal. For example, see "Frame Head" on page 37, "point i" only.

\*\*\* R<sub>w</sub> Ratings indicated in the table above are based on Blankfort 30 core. If Halspan core is used in lieu of Blankfort, a reduction of 1dB can be expected to the R<sub>w</sub> Rating, e.g. Blankfort 30 R<sub>w</sub> Rating fully caulked = 34dB; Halspan (44 mm) R<sub>w</sub> Rating fully caulked = 33dB.

# What's in the ALU60 Kit?

Product components explained.

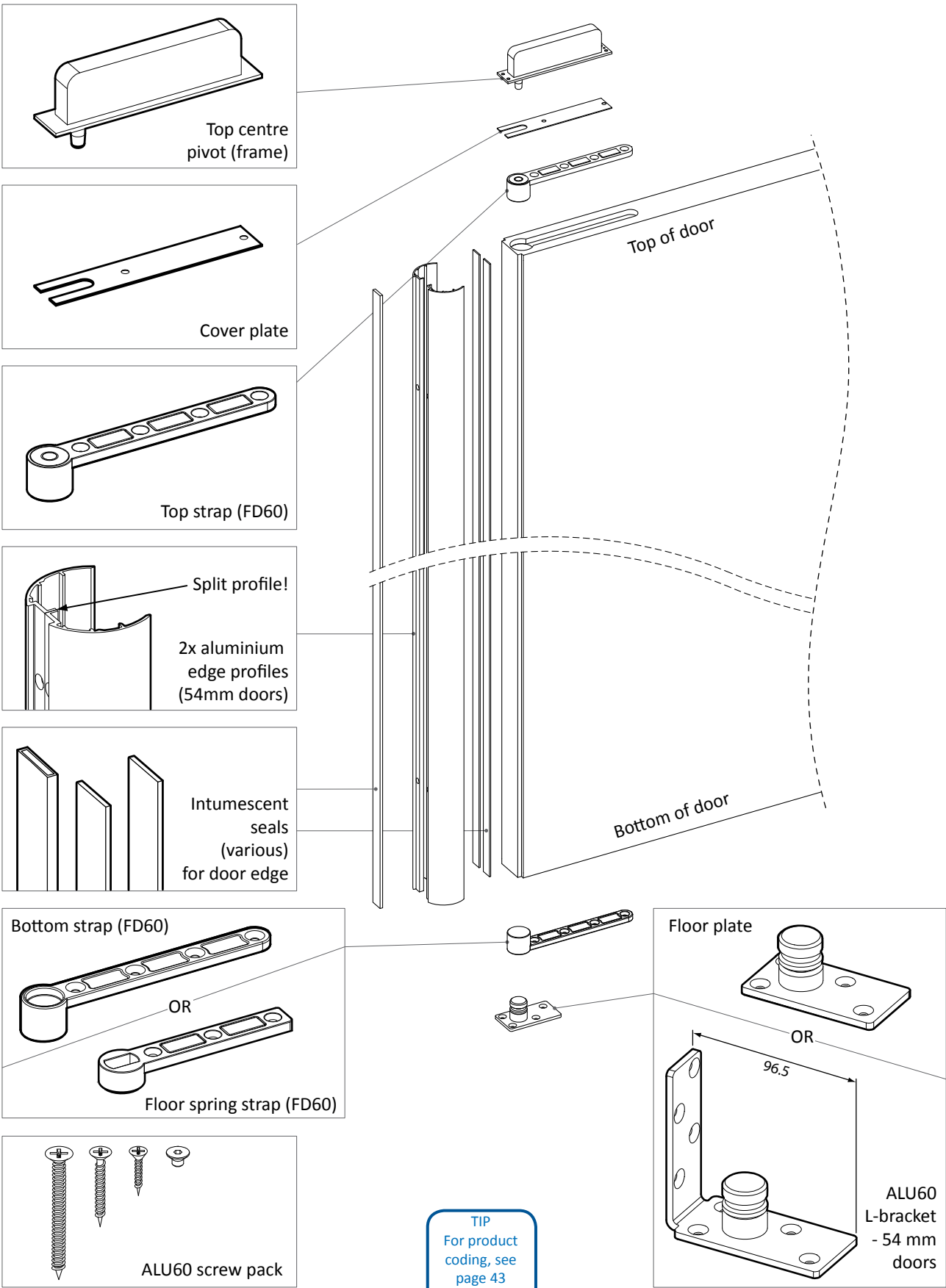

**TIP**  
 For product coding, see page 43

# ALU60 Doorset Dimensions

The guide below will help you work out the overall doorset dimensions using the frame width, clear opening width or preferred door leaf dimension as the starting point.

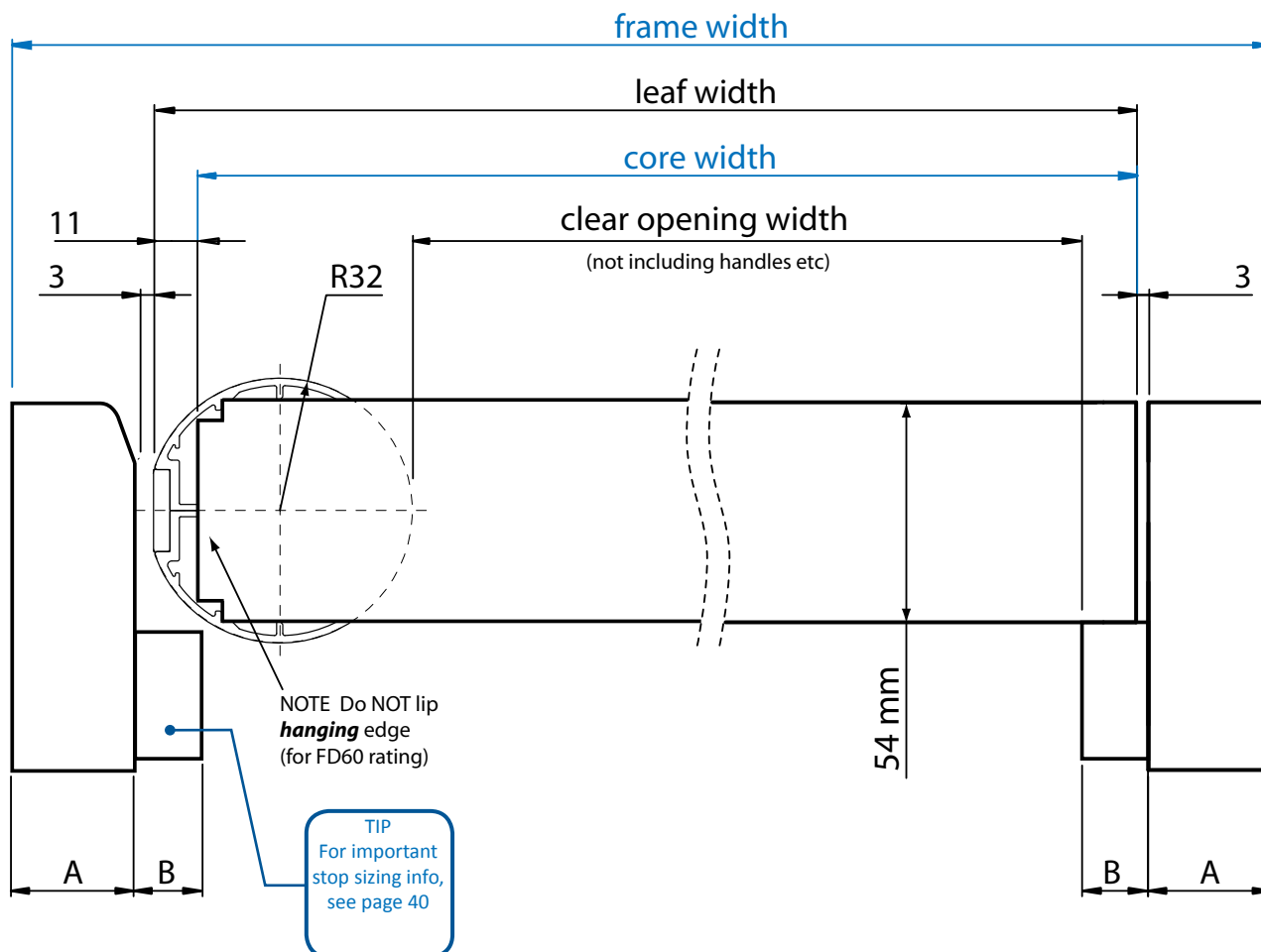

## Frame width ↔ Clear opening width:

$$\text{Clear opening width} = \text{Frame width} - 2A - B - 67$$

$$\text{Frame width} = \text{Clear opening width} + 2A + B + 67$$

EXAMPLE:

$$\begin{aligned} \text{Clear opening width} &= 1017 \text{ mm} - (2 \times 30 \text{ mm}) - 15 \text{ mm} - 67 \text{ mm} \\ &= 875 \text{ mm} \end{aligned}$$

## Frame width ↔ Leaf width:

$$\text{Leaf width} = \text{Frame width} - 2A - 6$$

$$\text{Frame width} = \text{Leaf width} + 2A + 6$$

EXAMPLE:

$$\text{Leaf width} = 1017 \text{ mm} - (2 \times 30 \text{ mm}) - 6 \text{ mm} = 951 \text{ mm}$$

## Clear opening width ↔ Leaf width:

$$\text{Leaf width} = \text{Clear opening width} + B + 61$$

$$\text{Clear opening width} = \text{Leaf width} - B - 61$$

EXAMPLE:

$$\text{Leaf width} = 875 \text{ mm} + 15 \text{ mm} + 61 \text{ mm} = 951 \text{ mm}$$

## Leaf width ↔ Lipped core width:

$$\text{Lipped core width} = \text{Leaf width} - 11 \text{ mm}$$

$$\text{Leaf width} = \text{Lipped core width} + 11 \text{ mm}$$

EXAMPLE:

$$\text{Lipped core width} = 951 \text{ mm} - 11 \text{ mm} = 940 \text{ mm}$$

# FD60 Fire Performance - Lorient



## Lorient Polyproducts - FD60 Maximum Leaf Sizes

Global Assessment Chilt/A10206 permits expansion of leaf sizes, alternative frame materials, glazing, door face finishes and various ancillaries, as summarised below. Please enquire if the information you require is not presented here.

### Latched, single acting, single leaf

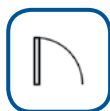

	S1	S2
<b>W</b>	850	979
<b>H</b>	2384	2100

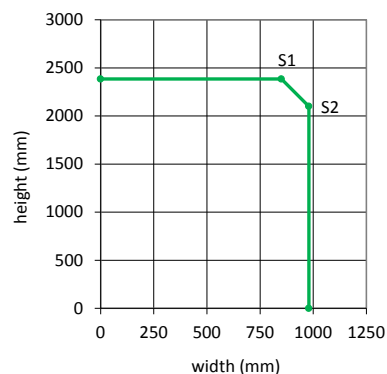

### Unlatched, single or double acting, single leaf



	S1	S2
<b>W</b>	850	954
<b>H</b>	2334	2100

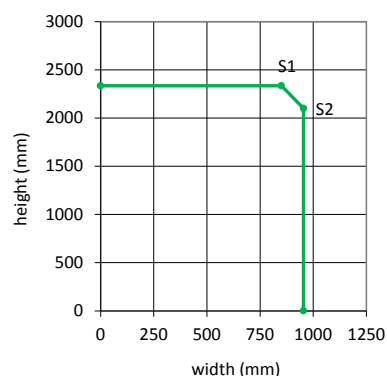

### Latched, single acting, double leaf



For unequal, double leaf – see “Unequal Double Leaf - Width Restrictions” on page 10.

	S1	S2
<b>W</b>	850	929
<b>H</b>	2284	2100

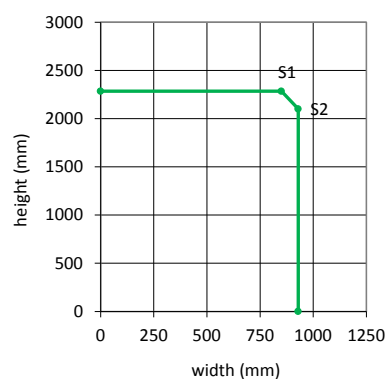

### Unlatched, single or double acting, double leaf



For unequal, double leaf – see “Unequal Double Leaf - Width Restrictions” on page 10.

	S1	S2
<b>W</b>	850	904
<b>H</b>	2234	2100

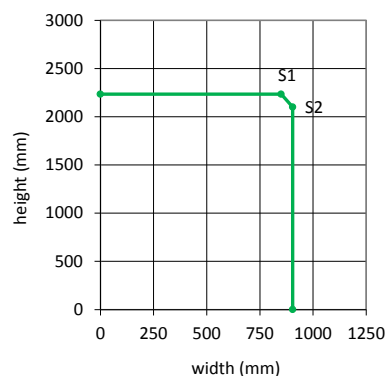

# Lorient Polyproducts - ALU60 Doorset Specification



## Unequal Double Leaf - Width Restrictions

Unequal leaf double doorsets are permitted with no restriction on the smaller leaf dimension, other than it must be within the maximum size envelope given in "Lorient Polyproducts - FD60 Maximum Leaf Sizes" on page 17.

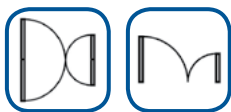

## Frame

Hardwood minimum density 640 kg/m<sup>3</sup>  
 Minimum sections excluding stops: 90 x 48 mm (head); 90 x 30 mm (jambs)  
 Head/jamb joint: mortice & tenon or half-lapped joint with head twice screwed to jambs; mitred joint glued with non-thermally softening adhesive (e.g. PU, UF, PVA) and twice screwed, or horizontal butt joint screwed with two screw fixings. No gaps.

## Stops

Machined from solid; pinned and glued, or pinned only.

## Recommended DD171 Severe Duty Frame

Minimum sections excluding stops: 90 x 48 (head); 90 x 30 (jambs). Hardwood only.  
 Head/jamb joint: butt jointed. Head to jambs fixed 3No. 3.5 mm x 100 mm screws per joint & PU glue.  
 Stops: 35x15 mm stops pinned at 200 mm centres with 40 mm pins, or integral.

## Door blank

Halspan (54 mm)  
 Blankfort 60 (54 mm)  
 Others cores permitted\* – contact Lorient Polyproducts (<http://www.lorientuk.com/>) for details.

\*currently Safehinge acoustic/mechanical testing conducted with Halspan / Blankfort cores only. If an alternative door core is used, Safehinge is unable to offer primary evidence to support acoustic/mechanical performance; this provision therefore becomes the responsibility of the specifier.

## Lipping

Hardwood minimum density 640 kg/m<sup>3</sup>  
 T-section lipping recommended - Halspan. Flat section - Blankfort (details - "Lipping Specification" on page 33).

## Gluelines

PU, UF, PVA, PF

## Intumescent/smoke seal

Frame seals (to be procured by door manufacturer):  
 Refer to "Table 5" and "Table 6" on page 19.

Door edge seals (supplied by Safehinge):  
 20x4 PVC-cased Type 617 (white) & 2No. 15x3 GPF graphite strip.

Ironmongery intumescent (supplied by Safehinge):  
 Graphite or Lorient M.A.P gasket wrap and dual pockets (for top centre pivot, top & bottom straps (both sides).

## Finishes

Timber veneers, paint finish, plastic/PVC laminate (maximum 2 mm thickness)

## Glazing

Doors fitted with Safehinge ALU30™ may be glazed subject to the fire resistance performance data available for the particular design.

# Lorient Polyproducts - ALU60 Seal Specification



## Single Door (Single/Double Acting)



		Seal Position (see "Frame Specification - Single Doors" on page 31)						Threshold	R <sub>w</sub> Rating (dB)
		Frame head		Hanging jamb		Closing Jamb			
Rating		A	B	C	D	E	F		
	<b>Fire, smoke &amp; acoustic (single acting only)</b>	20x4 LP2004 Type 617 & IS1212*	20x4 LP2004DS Type 617	10x4 LP1004DS Type 617	10x4 LP1004 Type 617 & Lorient IS1511 Firtree*	Same as B	Same as A	Options: 1) 2x Lorient IS1511* 2) Lorient IS8091si*	Up to 38dB. For exact rating - see "Table 9" on page 37
	<b>Fire &amp; smoke</b>	20x4 LP2004 Type 617	20x4 LP2004DS Type 617**	10x4 LP1004DS Type 617	10x4 LP1004 Type 617	Same as B	Same as A	Refer BS9999:2008 (33.1.7)	N/A
<b>Fire only</b>	20x4 LP2004 Type 617	Same as A	10x4 LP1004 Type 617	Same as C	Same as A	Same as A	N/A	N/A	
Position	<b>Single acting</b>	Fit A and B spaced 5mm, central to door		Fit C and D spaced 5mm, <b>offset</b>		Fit E and F spaced 5mm, central to door			
	<b>Double acting</b>	Fit A and B spaced 5mm, central to frame		Fit C and D spaced 5mm, central to frame		Fit E and F spaced 5mm, central to frame			

Table 5

## Double Doors (Single/Double Acting)



		Seal Position (see "Frame Specification - Double Doors" on page 32)						Threshold
		Frame head		Hanging jamb		Meeting edge		
Rating		A	B	C	D	G	H	
	<b>Fire &amp; smoke</b>	20x4 LP2004 Type 617	20x4 LP2004DS Type 617**	10x4 LP1004DS Type 617	10x4 LP1004 Type 617	15x4 LP1504DS Type 617	Same as G	Refer BS9999:2008 (33.1.7)
	<b>Fire only</b>	20x4 LP2004 Type 617	Same as A	10x4 LP1004 Type 617	Same as C	15x4 LP1504 Type 617	Same as G	N/A
Position	<b>Single acting</b>	Fit A and B spaced 5mm, central to door		Fit C and D spaced 5mm, <b>offset</b>		Fit G and H spaced 10mm, central to door		
	<b>Double acting</b>	Fit A and B spaced 5mm, central to frame		Fit C and D spaced 5mm, central to frame		Fit G and H spaced 10mm, central to door		

Table 6

\* Details: "ALU60 Acoustic Seal Option Drawings" on page 37.

\*\* For double swing doors, IS1511 recommended (to door head) to bridge interruption in frame head seal. For example, see "Frame Head" on page 37, "point i" only.

# FD60 Fire Performance - ISL



## Intumescent Seals Ltd - FD60 Maximum Leaf Sizes

Field of Application Report PAR/9574/01 permits expansion of leaf sizes, alternative frame materials, glazing, door face finishes and various ancillaries, as summarised below. Please enquire if the info you require is not presented here.

### Latched, single acting, single leaf



	S1	S2
<b>W</b>	782	1026
<b>H</b>	2574	2100

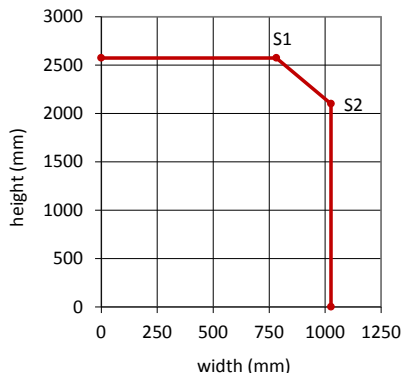

### Unlatched, single or double acting, single leaf



	S1	S2
<b>W</b>	767	1014
<b>H</b>	2524	2029

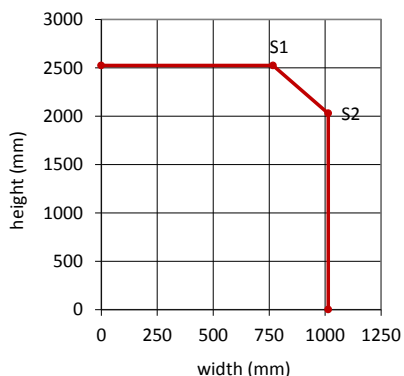

### Latched, single acting, double leaf



For unequal, double leaf – width restrictions apply.

See "Unequal Double Leaf - Width Restrictions" on page 21.

	S1	S2
<b>W</b>	829	983
<b>H</b>	2314	2006

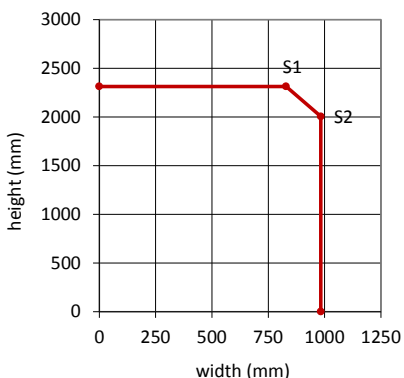

### Unlatched, single or double acting, double leaf



For unequal, double leaf – width restrictions apply.

See "Unequal Double Leaf - Width Restrictions" on page 21.

	S1	S2
<b>W</b>	821	973
<b>H</b>	2291	1986

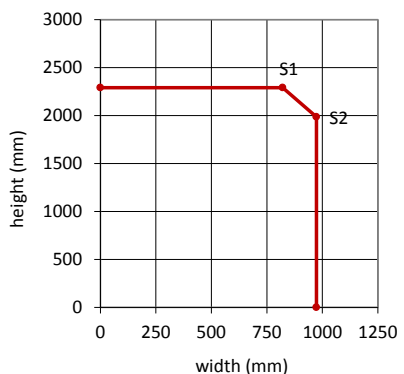

# Intumescent Seals Ltd - ALU60 Doorset Specification



## Unequal Double Leaf - Width Restrictions

In double leaf assemblies (single or double acting) each leaf is permitted to be of the same width, up to the maximum width given in "Intumescent Seals Ltd - FD60 Maximum Leaf Sizes" on page 20.

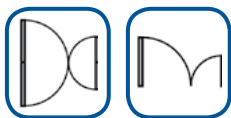

If leaves are both unlatched/unbolted and of unequal width, the small leaf must be no more than 550 mm narrower than the large leaf. This is to reduce the level of differential deflection in fire. If the smaller leaf is bolted, then there is no limit on the ratio of leaf widths, although the large leaf must still be within the maximum size envelope.

In all instances, the width of the small leaf must not be less than 300 mm wide.

## Frame

Hardwood minimum density 640 kg/m<sup>3</sup>  
 Minimum sections excluding stops: 75 x 48 mm (head); 75 x 30 mm (jambs)  
 Head/jamb joint: mortice & tenon or half-lapped joint with head twice screwed to jambs; mitred joint glued with non-thermally softening adhesive (e.g. PU, UF, PVA) and twice screwed, or horizontal butt joint screwed with three screw fixings.

## Stops

Machined from solid; pinned and glued, or pinned only.

## Recommended DD171 Severe Duty Frame

Minimum sections excluding stops: 90 x 48 (head); 90 x 30 (jambs). Hardwood only.  
 Head/jamb joint: butt jointed. Head to jambs fixed 3No. 3.5 mm x 100 mm screws per joint & PU glue.  
 Stops: 35x15 mm stops pinned at 200 mm centres with 40 mm pins, or integral.

## Door blank

Halspan (54 mm) only

## Lipping

Hardwood minimum density 640 kg/m<sup>3</sup>  
 T-section lipping recommended - Halspan (details - "Lipping Specification" on page 33).

## Gluelines

PU, UF, melamine-UF, cross-linked PVA, PVA, PF

## Intumescent/smoke seal

Frame seals (to be procured by door manufacturer):  
 Refer to "Table 7" and "Table 8" on page 22.

Door edge seals (supplied by Safehinge):

20x4 PVC-cased Therm-a-seal (white), 2No. 19x2 Therm-a-strip (white), 2No. 17x2 Therm-a-line (pink) & 2No. 8x2 Therm-a-flex (black).

Ironmongery intumescent (supplied by Safehinge):

Graphite gasket wrap and pockets  
 (for top centre pivot & top strap)

## Finishes

Timber veneers, paint finish, plastic/PVC laminate  
 (maximum 2 mm thickness)

## Glazing

Maximum area of apertures: 0.39m<sup>2</sup>  
 Maximum vertical length of aperture: 1540 mm  
 Maximum horizontal length of aperture: 300 mm  
 Minimum distance from leaf edge (sides): 100 mm  
 Minimum distance from bottom of leaf: 200 mm

More than one aperture may be included in each leaf subject to the above limitations. The minimum distance between apertures is 100 mm. Aperture shape is not restricted provided the glazing system and beads are compatible with that shape.

A wide range of glazing systems are permitted. Please contact Technical Support for details.

# Intumescent Seals Ltd - ALU60 Seal Specification



## Single Door (Single/Double Acting)

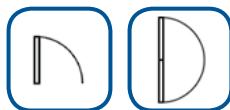

		Seal Position (see "Frame Specification - Single Doors" on page 31)							
		Frame head		Hanging jamb		Closing Jamb		Threshold	R <sub>w</sub> Rating (dB)
		A	B	C	D	E	F		
Rating	<b>Fire, smoke &amp; acoustic</b> (single acting only)	20x4 Therm-a-seal & NOR710*	20x4 Therm-a-blade	10x4 Therm-a-blade	10x4 Therm-a-seal & Lorient IS1511 Firtree*	Same as B	Same as A	Options: 1) 2x Lorient IS1511* 2) Lorient IS8091si*	Up to 38dB. For exact rating - see "Table 9" on page 37
	<b>Fire &amp; smoke</b>	20x4 Therm-a-seal	20x4 Therm-a-blade**	10x4 Therm-a-blade	10x4 Therm-a-seal	Same as B	Same as A	Refer BS9999:2008 (33.1.7)	N/A
	<b>Fire only</b>	20x4 Therm-a-seal	Same as A	10x4 Therm-a-seal	Same as C	Same as A	Same as A	N/A	N/A
Position	<b>Single acting</b>	Fit A and B spaced 5mm, central to door		Fit C and D spaced 5mm, <b>offset</b>		Fit E and F spaced 5mm, central to door			
	<b>Double acting</b>	Fit A and B spaced 5mm, central to frame		Fit C and D spaced 5mm, central to frame		Fit E and F spaced 5mm, central to frame			

Table 7

## Double Doors (Single/Double Acting)



		Seal Position (see "Frame Specification - Double Doors" on page 32)						
		Frame head		Hanging jamb		Meeting edge		Threshold
		A	B	C	D	G	H	
Rating	<b>Fire &amp; smoke</b>	20x4 Therm-a-seal	20x4 Therm-a-blade**	10x4 Therm-a-blade	10x4 Therm-a-seal	15x4 Therm-a-blade	Same as G	Refer BS9999:2008 (33.1.7)
	<b>Fire only</b>	20x4 Therm-a-seal	Same as A	10x4 Therm-a-seal	Same as C	15x4 Therm-a-seal	Same as G	N/A
Position	<b>Single acting</b>	Fit A and B spaced 5mm, central to door		Fit C and D spaced 5mm, <b>offset</b>		Fit G and H spaced 5mm, central to door		
	<b>Double acting</b>	Fit A and B spaced 5mm, central to frame		Fit C and D spaced 5mm, central to frame		Fit G and H spaced 5mm, central to door		

Table 8

\* Details: "ALU60 Acoustic Seal Option Drawings" on page 37.  
 \*\* For double swing doors, IS1511 recommended (to door head) to bridge interruption in frame head seal. For example, see "Frame Head" on page 37, "point i" only.

NOTE - ISL seals can only be used with Halspan core at FD60.



**safehinge**<sup>TM</sup>  
Manufacturing Guidelines

# ALU30 Manufacturing Guidelines

## Frame Specification - Single Doors

### Single Door (Single Acting)



Asterisk (\*) indicates the minimum recommended size.

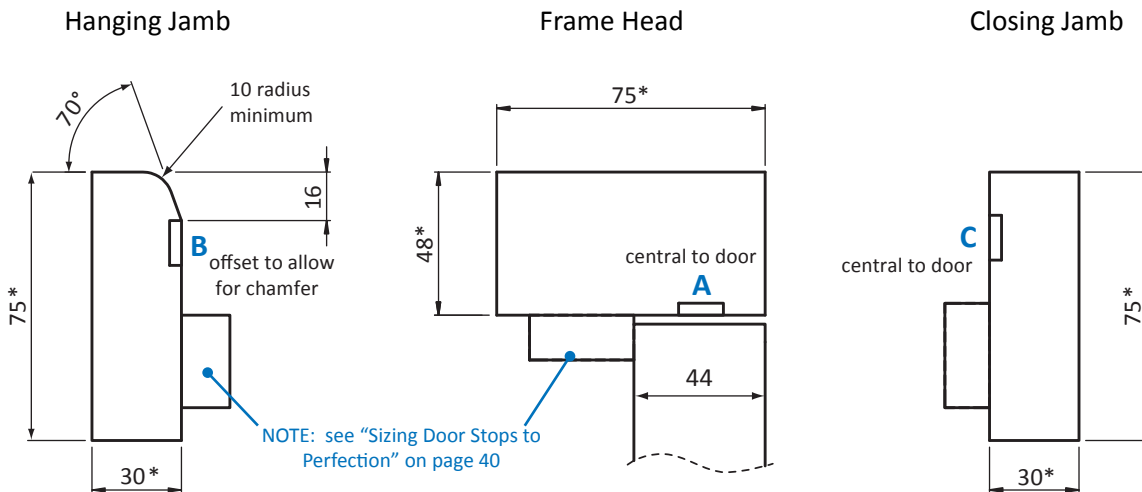

### Single Door (Double Acting)



Seal spec - See "Table 1" on page 11 (Lorient) or "Table 3" on page 14 (ISL)

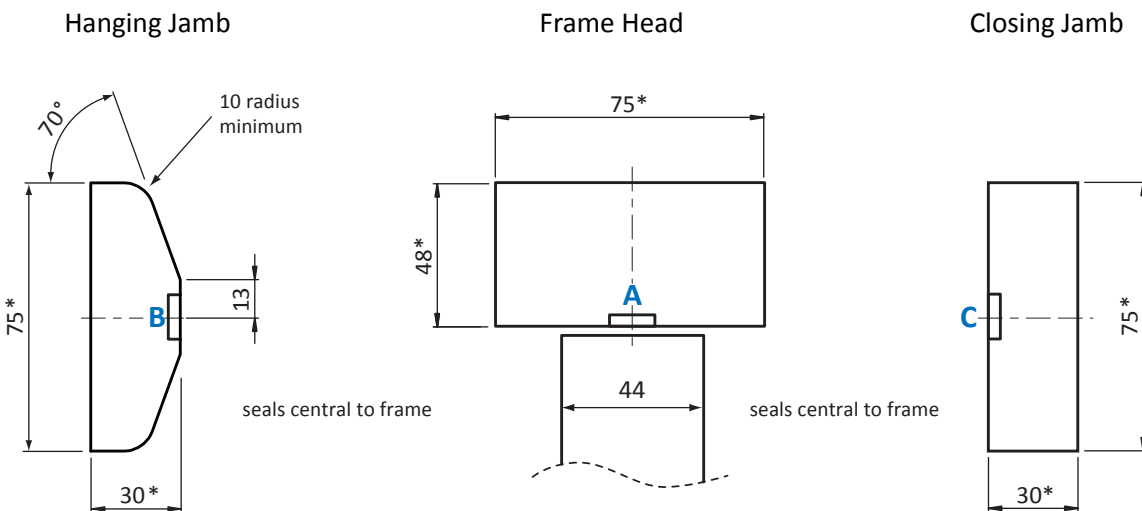

### Frame Assembly Details

**Permitted frame materials (FD30):** Softwood or hardwood minimum density 510 kg/m<sup>3</sup>. MDF minimum density 700 kg/m<sup>3</sup> (MDF frames may consist of laminated sections to achieve required width dimensions. PU adhesive recommended.) **IMPORTANT:** See "Recommended DD171 Severe Duty Frame" on page 25.

**Head/jamb joint:** mortice & tenon or half-lapped joint with head twice screwed to jambs; mitred joint glued with non-thermally softening adhesive (e.g. PU, UF, PVA) and twice screwed, or horizontal butt joint screwed with two screw fixings.

**Stops:** Machined from solid; pinned and glued, or pinned only.

# Frame Specification - Double Doors

## Double Door (Single Acting)



Asterisk (\*) indicates the minimum recommended size.

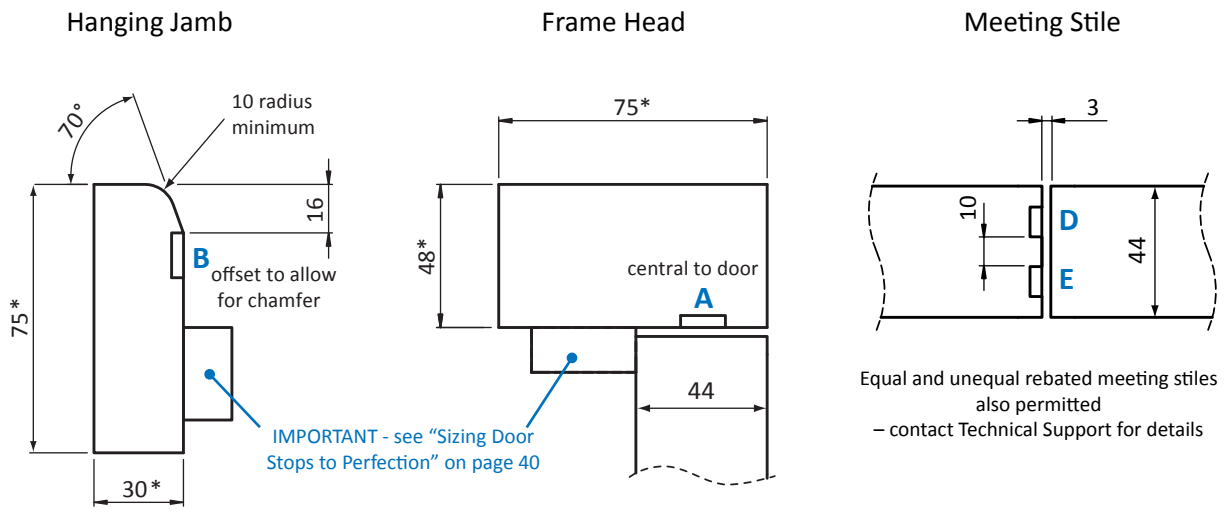

## Double Door (Double Acting)

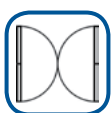

Seal spec - See "Table 2" on page 11 (Lorient) or "Table 4" on page 14 (ISL)

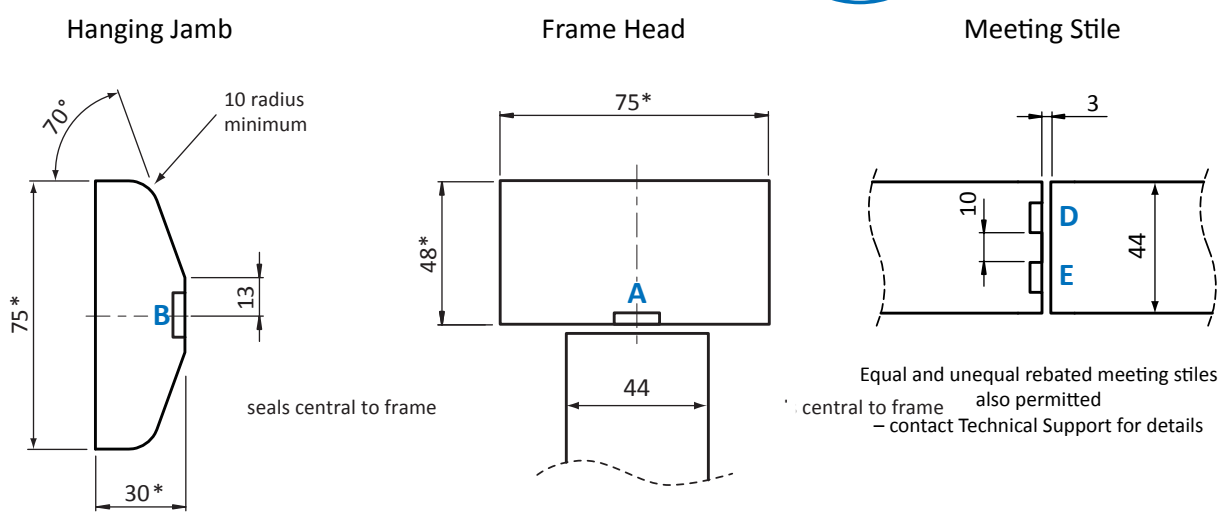

### Recommended DD171 Severe Duty Frame

Safehinge recommends the following specification for heavy/severe duty applications.

- Frame:** minimum section 90 x 48 (head) and 90 x 30 (jamb). MDF or hardwood.
- Frame joints:** butt jointed. Head to jambs fixed using 3No. 3.5 mm x 100 mm screws per joint & PU glue.
- Stops:** 35x15 mm stops pinned at 200 mm centres with 40 mm pins, or integral.

## Lipping Specification

The recommended lipping sections and gap sizes for Halspan and Blankfort door blanks are shown below.

### Halspan (44 mm)



Head & Threshold

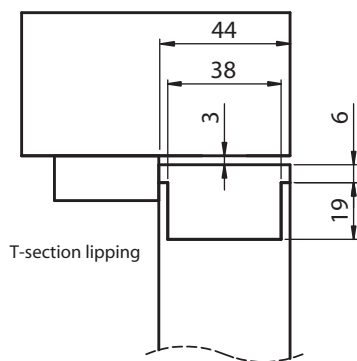

Jambs

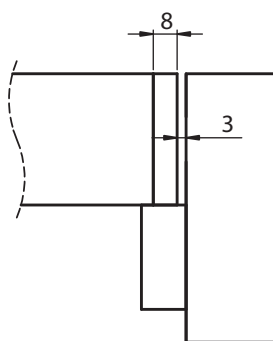

NOTE: T-section lipping is **essential** to ensure mechanical stability of doorset when using particleboard core. Safehinge has achieved DD171 "Severe Duty" rating with the configuration shown.

### Blankfort (45 mm)



Head & Threshold

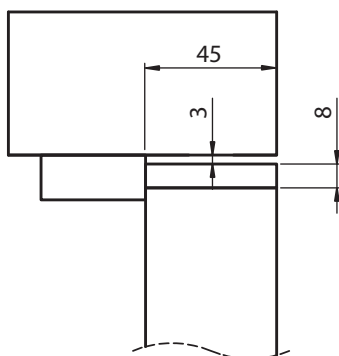

Jambs

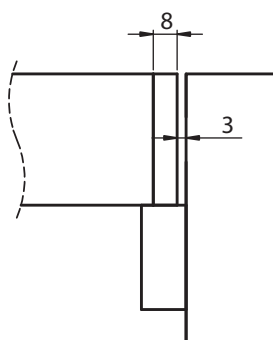

Lorient seals only: 6 - 10 mm lipping permitted with Blankfort (45 mm).

### Lipping Details

Hardwood minimum density 640 kg/m<sup>3</sup>

Gluelines: PU, UF, melamine-UF, cross-linked PVA, PVA, PF

## Rebate & Mortice Details

**IMPORTANT:** Care should be taken to position rebates/mortices correctly as these influence the finger-safe gap between the door and the frame.

### 1. Aluminium Edge Profile Rebate

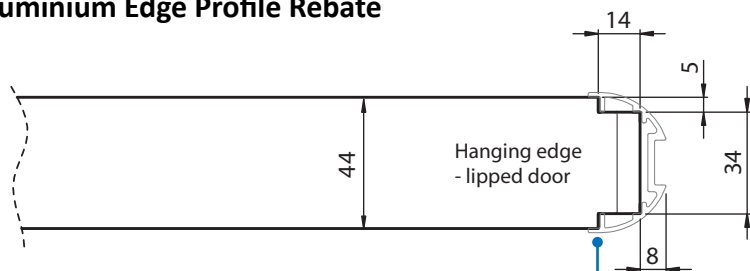

Apply to hanging side only of pre-lipped door leaf.

**IMPORTANT:** aluminium edge profile and pivot strap must have same centre point and be concentric.

### 2. Pivot Strap Mortice

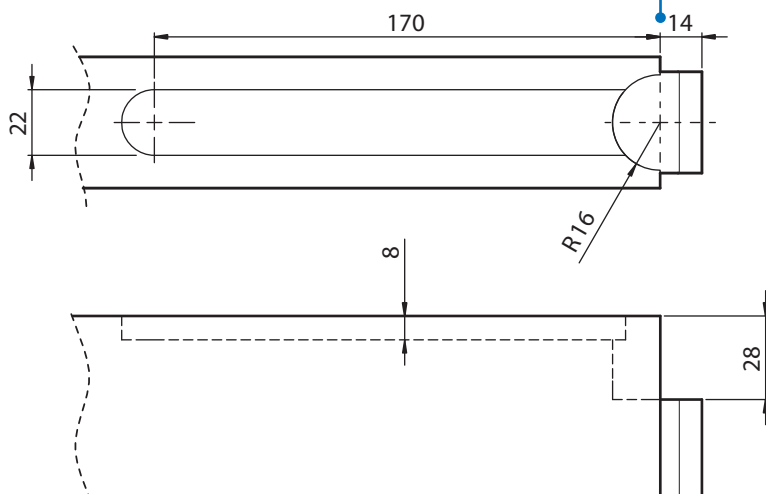

Mortice detail for pivot strap - same at head and threshold of door.

If using a floor spring, this requires an alternative bottom strap. See "Floor Spring with ALU30 kits" on page 28

### 3. Top Centre Pivot Mortice

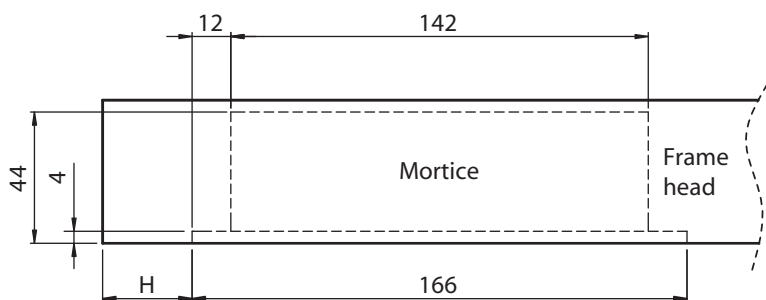

Mortice to frame head.

H = frame jamb width  
e.g. H = 30 mm

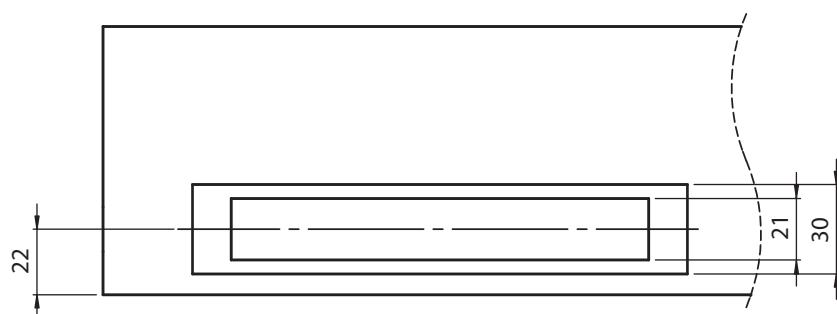

**NOTE:** mortice position shown assumes single swing (opening face of door to sit flush with opening face of frame).

Mortice should be centred on frame for double swing.

# Floor Spring with ALU30 kits

## Floor Spring Strap Mortise for ALU30

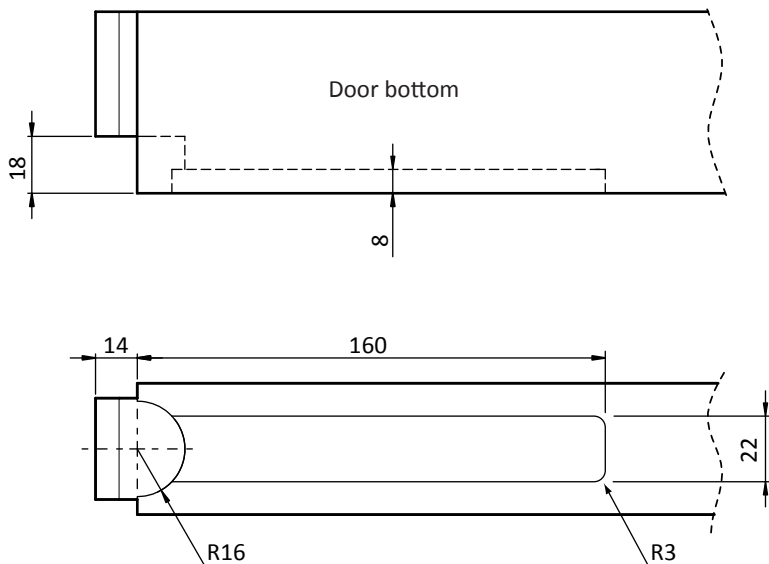

**TIP**  
When using a floor spring the bottom strap mortise changes as shown here. Remaining rebate / mortise details are the same as regular ALU30 kit (see page 27).

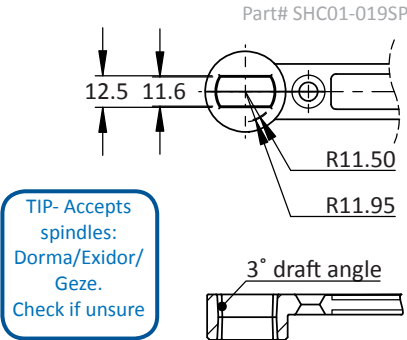

## Floor Spring Layout with ALU30

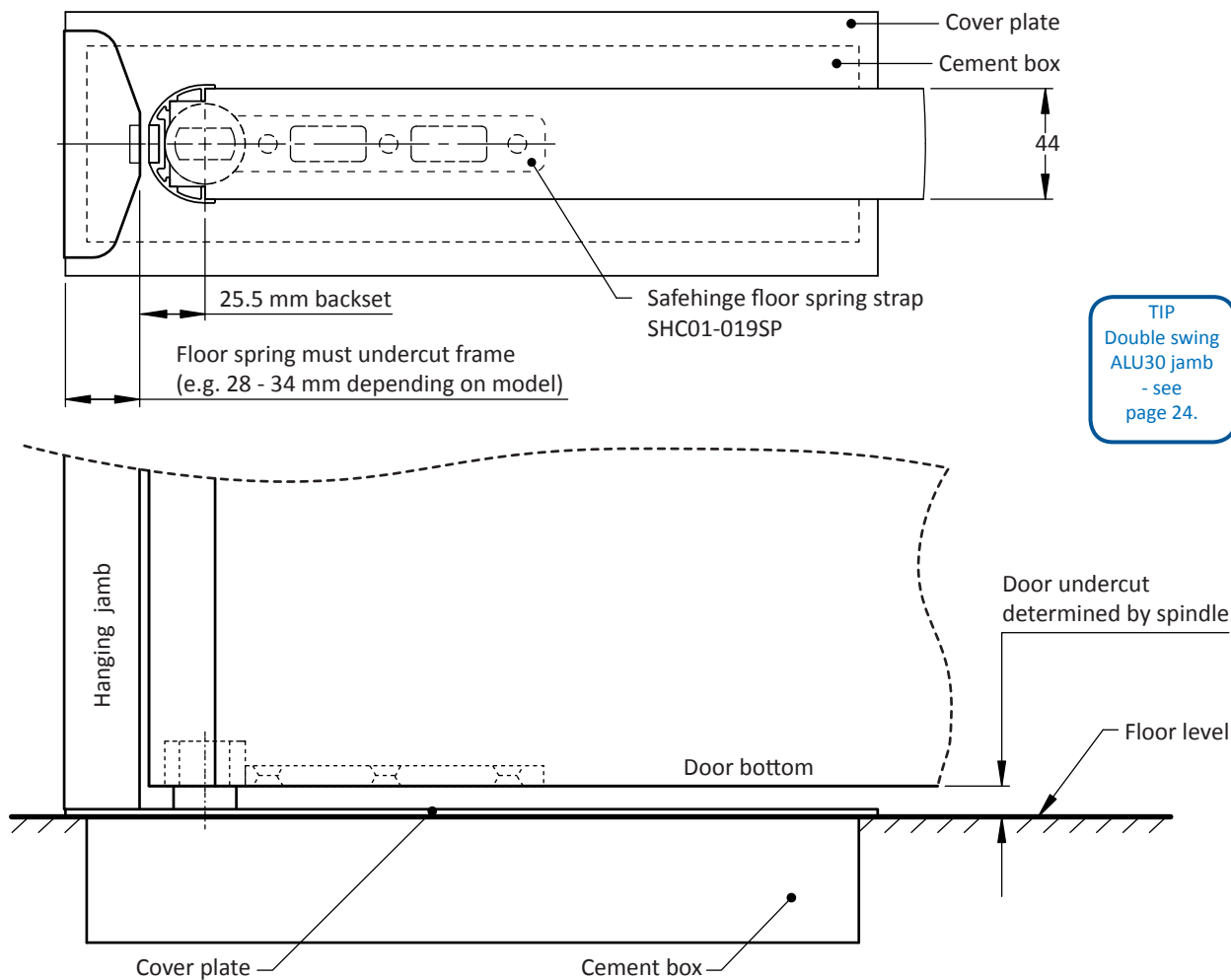

## Floor Pivot Positioning (44 mm doors)

Care should be taken to position components correctly as these will influence the finger safe gap between the door and the frame.

### Floor Plate (ALU30-100 kits)

Positioning shown - 44 mm (ALU30) doors only.

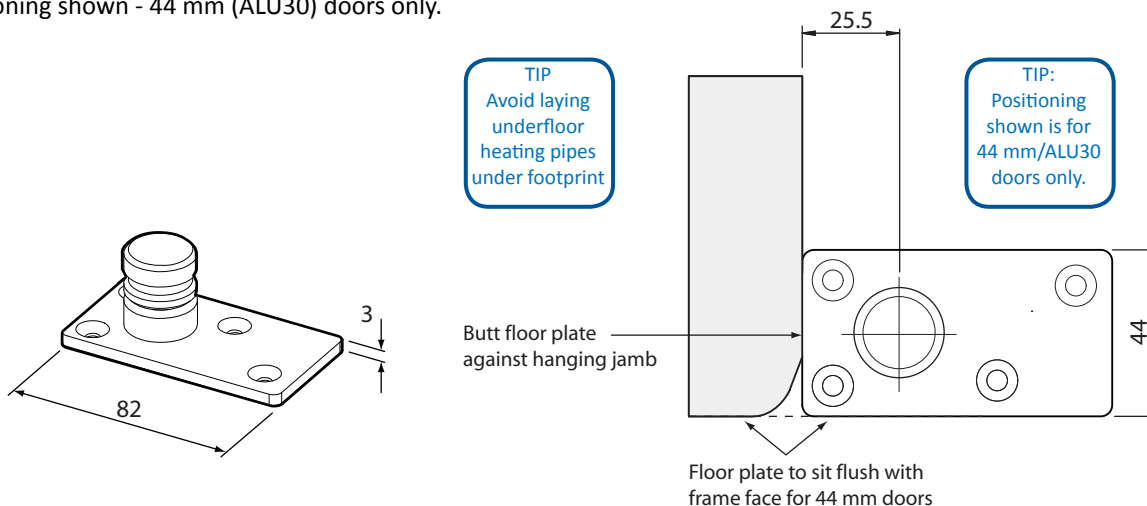

### L-Bracket for 44 mm doors (ALU30-150 kits)

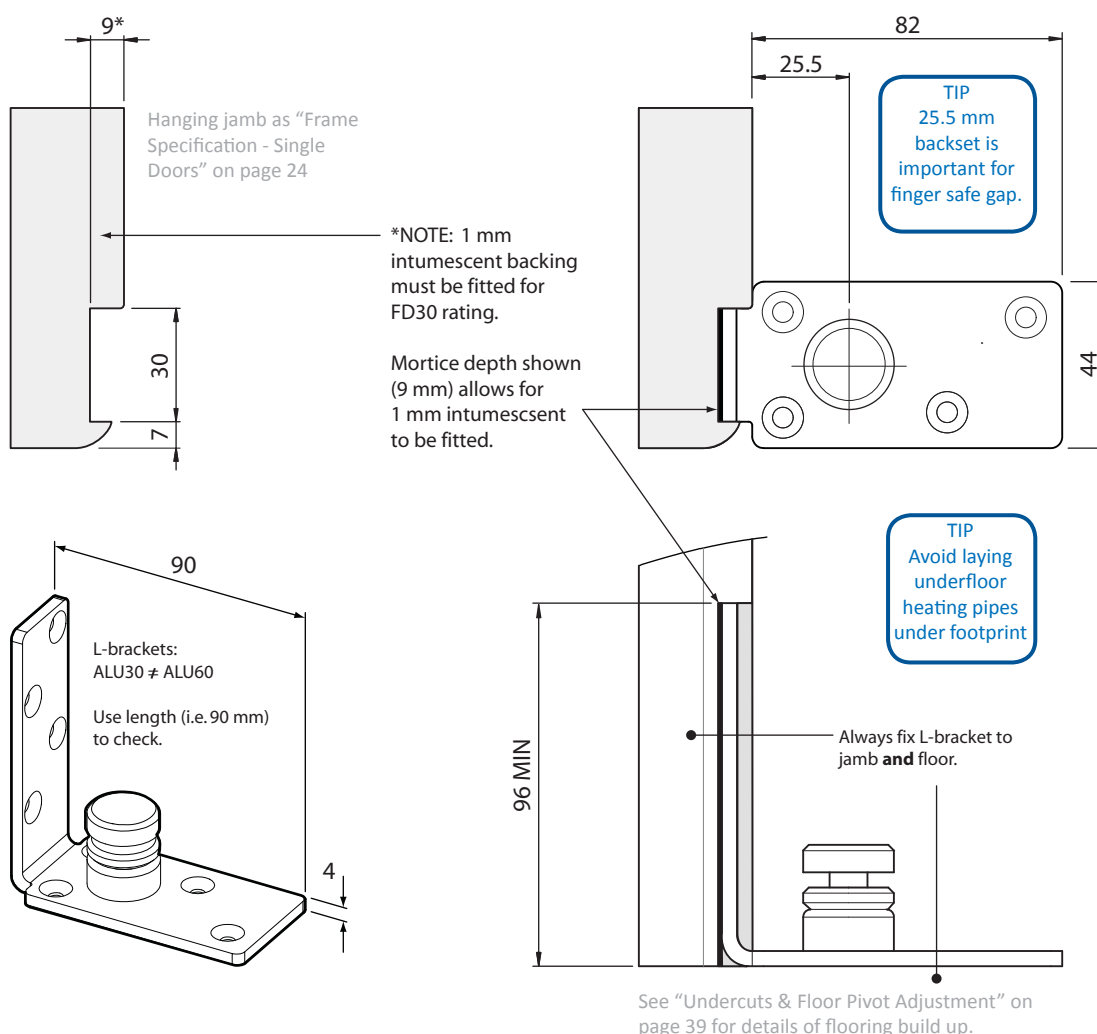

# ALU30 Acoustic Seal Option Drawings

PLEASE NOTE: This page only shows the placement of ALU30 **acoustic** seals which are **additional** to the combined intumescent smoke seals (A - C), detailed under "Lorient Polyproducts - ALU30 Seal Specification" on page 11 or "Intumescent Seals Ltd - ALU30 Seal Specification" on page 14.

## Option 1 & 2

Lorient IS1511  
6mm firtree

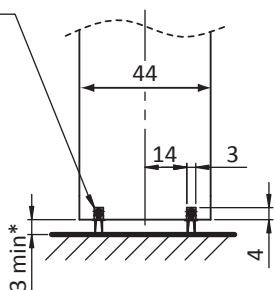

\*if greater than 3mm - recommend compatible raised threshold plate

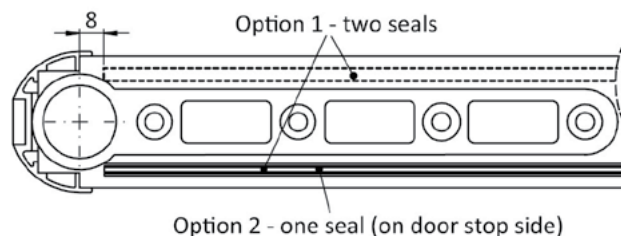

## Option 3

Lorient IS8090si or IS8035si  
face-fixed drop seal

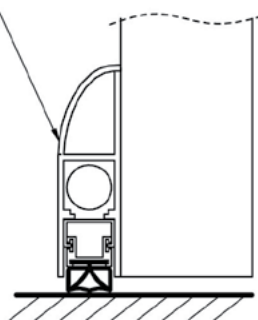

## Option 4

Lorient IS3080 si or IS3081si

**Options 3 & 4:** size the face-mounted seal to butt against the aluminium edge profile on the hanging side and leave a clearance gap on the closing side as per the manufacturer's instructions.

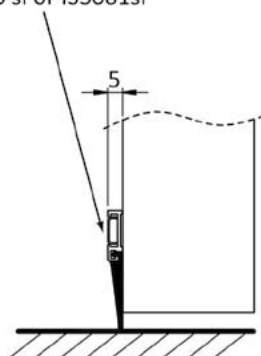

## Option 5

Norsound  
NOR855

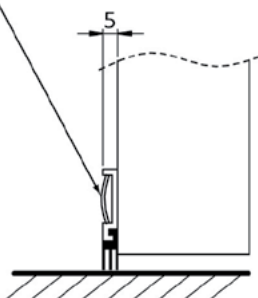

## Option 6 (Frame Head / Closing Jamb)

Lorient IS1212

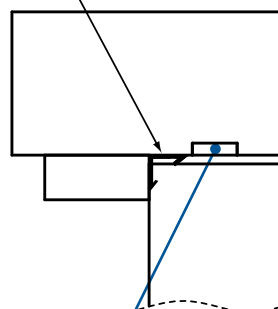

## Option 7 (Frame Head / Closing Jamb)

Norsound NOR710

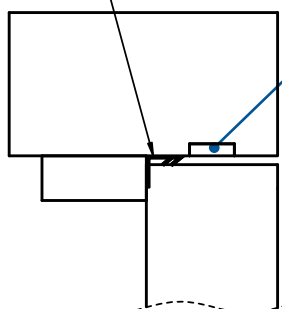

For other perimeter seal spec - page 11 (Lorient) or page 14 (ISL)

# ALU60 Manufacturing Guidelines

## Frame Specification - Single Doors

### Single Door (Single Acting)



Asterisk (\*) indicates the minimum recommended size.

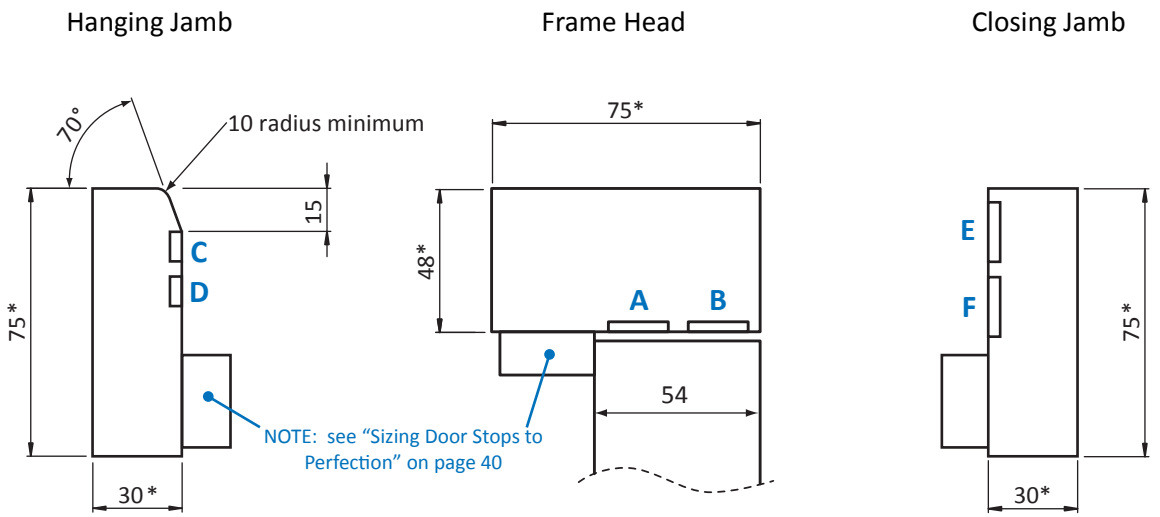

### Single Door (Double Acting)



Seal spec - See "Table 5" on page 19 (Lorient) or "Table 7" on page 22 (ISL)

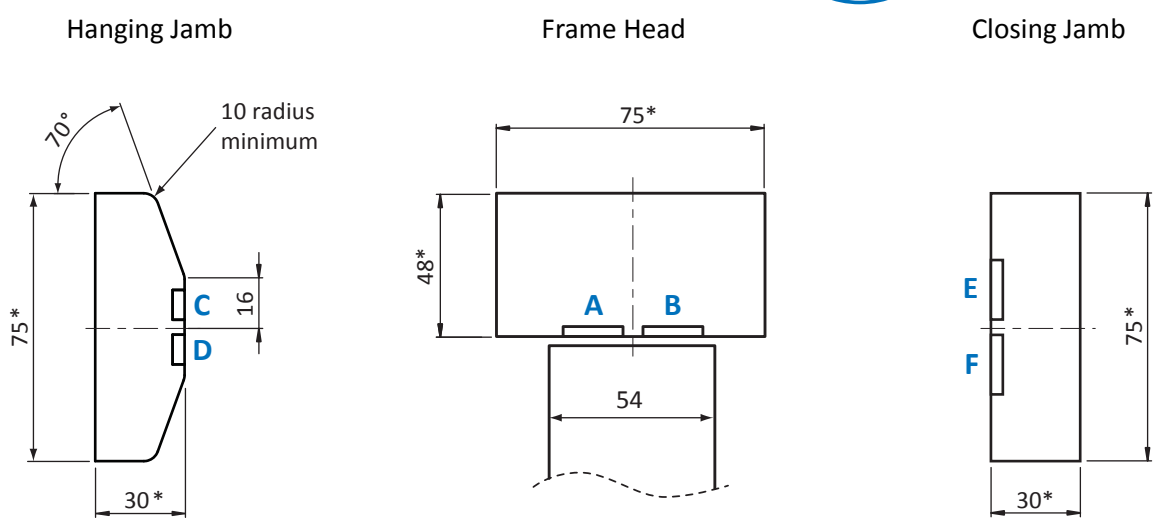

### Frame Assembly Details

*Permitted frame materials (FD60):* Hardwood minimum density 640 kg/m<sup>3</sup>.

**IMPORTANT:** See "Recommended DD171 Severe Duty Frame" on page 32.

*Head/jamb joint:* mortice & tenon or half-lapped joint with head twice screwed to jambs; mitred joint glued with non-thermally softening adhesive (e.g. PU, UF, PVA) and twice screwed, or horizontal butt joint screwed with two screw fixings.

*Stops:* Machined from solid; pinned and glued, or pinned only.

# Frame Specification - Double Doors

## Double Door (Single Acting)



Asterisk (\*) indicates the minimum recommended size.

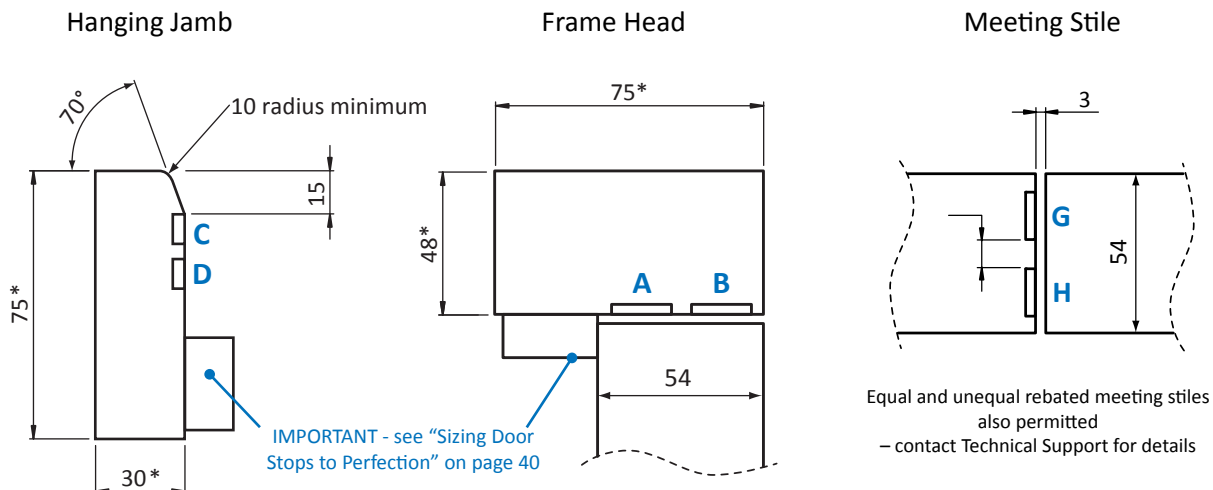

## Double Door (Double Acting)

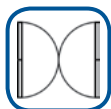

Seal spec - See "Table 6" on page 19 (Lorient) or "Table 8" on page 22 (ISL)

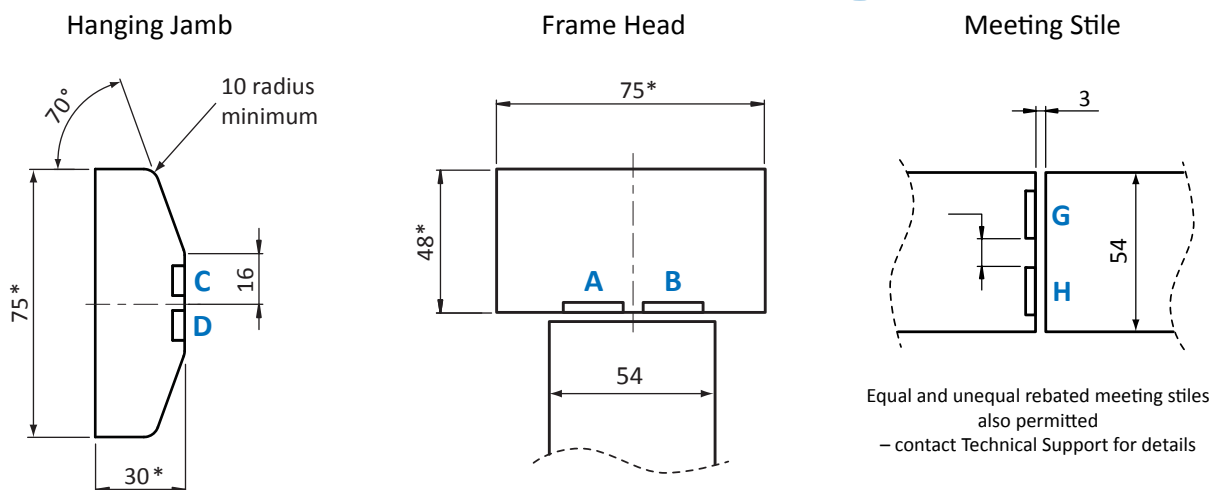

### Recommended DD171 Severe Duty Frame

Safehinge recommends the following specification for heavy/severe duty applications.

*Frame:* minimum section 90 x 48 (head) and 90 x 30 (jambs). Hardwood.

*Frame joints:* butt jointed. Head to jambs fixed using 3No. 3.5 mm x 100 mm screws per joint & PU glue.

*Stops:* 35x15 mm stops pinned at 200 mm centres with 40 mm pins, or integral.

# Lipping Specification

The recommended lipping sections and gap sizes for Halspan and Blankfort door blanks are shown below.

## Halspan (54 mm)



Head & Threshold

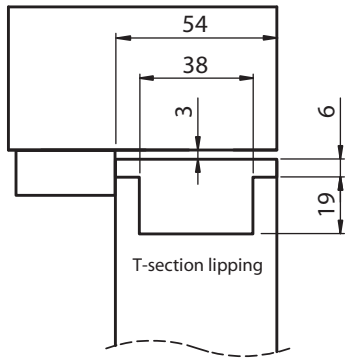

**TIP**  
T-section lipping is essential to ensure mechanical stability of doorset when using particleboard core.  
Safehinge has achieved DD171 "Severe Duty" rating with the configuration shown.

## Blankfort 60 / 60+ (54 mm)



Head & Threshold

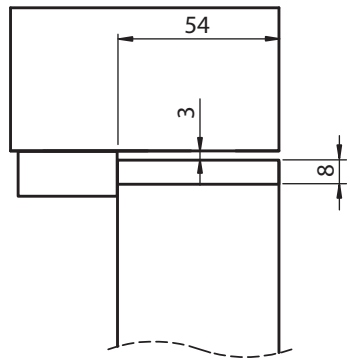

### Shared detail: Halspan (54 mm) and Blankfort 60 / 60+

Hanging Edge

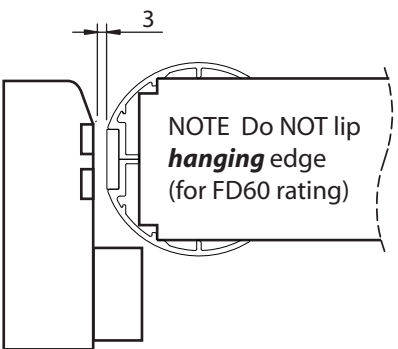

**TIP**  
DO NOT lip the hanging edge for FD60 rating.  
This detail applies to both Halspan and Blankfort cores.

Closing Edge

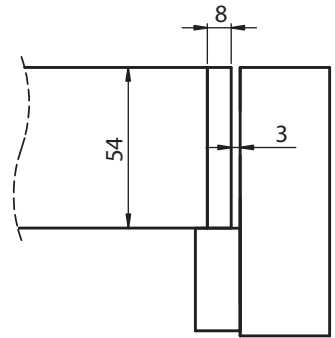

### Lipping Details

Hardwood minimum density 640 kg/m<sup>3</sup>  
Gluelines: PU, UF, melamine-UF, cross-linked PVA, PVA, PF

## Rebate & Mortice Details

**IMPORTANT:** Care should be taken to position rebates/mortices correctly as these influence the finger-safe gap between the door and the frame.

### 1. Aluminium Edge Profile Rebate

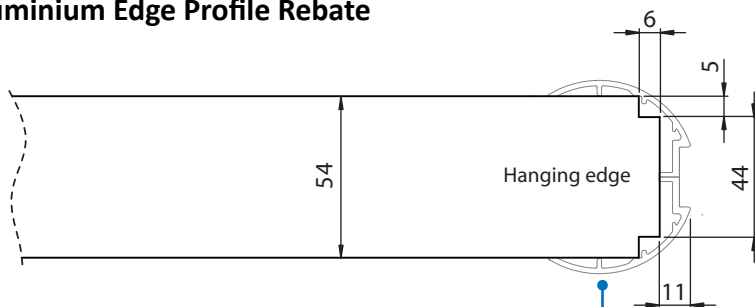

Apply to hanging edge only of door leaf.

**NOTE:** hanging edge un-lipped for FD60 rating.

### 2. Pivot Strap Mortice

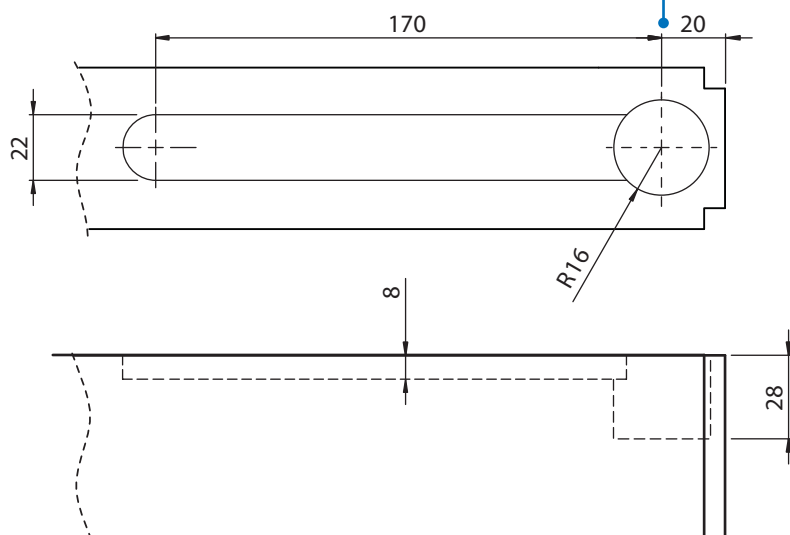

**IMPORTANT:** aluminium edge profile and pivot strap must have same centre point and be concentric.

Mortice detail for pivot strap - same at head and threshold of door.

If using a floor spring, this requires an alternative bottom strap. See "Floor Spring with ALU60 kits" on page 35

### 3. Top Centre Pivot Mortice

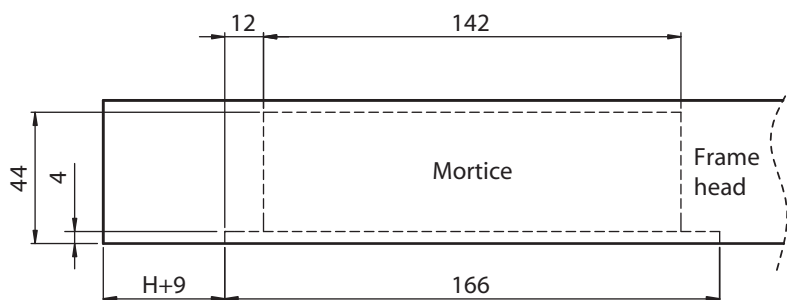

Mortice to frame head.

H = frame jamb width

e.g. H = 30 mm

H+9 = 39 mm

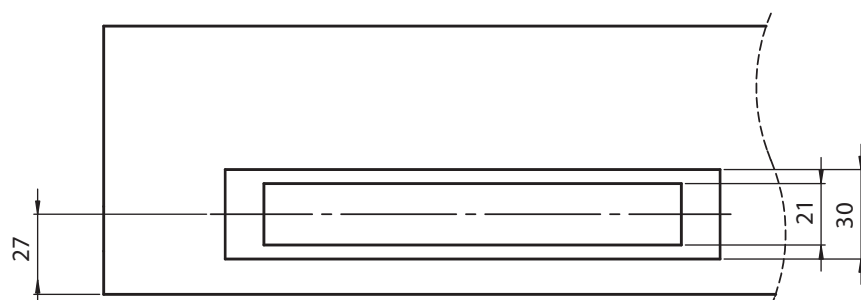

**NOTE:** mortice shown assumes opening face of door is required to sit flush with opening face of frame.

# Floor Spring with ALU60 kits

## Floor Spring Strap Mortice for ALU60

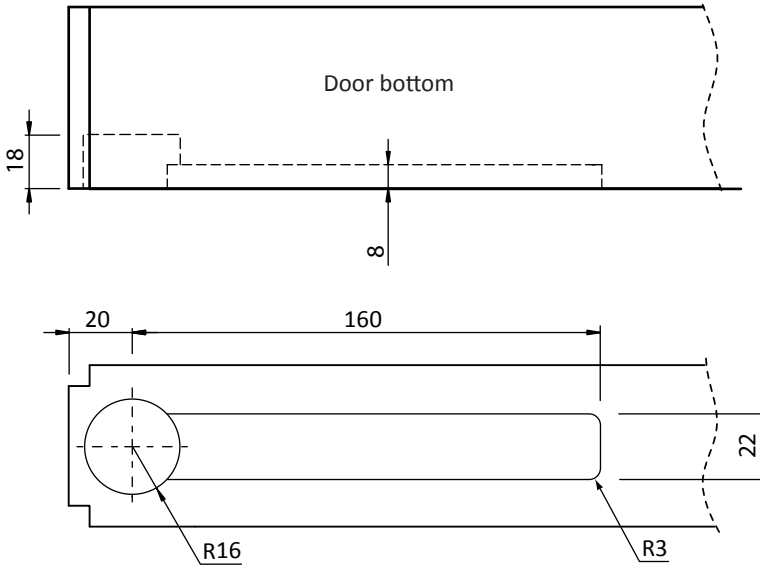

**TIP**  
When using a floor spring the bottom strap mortice changes as shown here. The remaining rebate / mortice details are the same as regular ALU60 kit (see page 34).

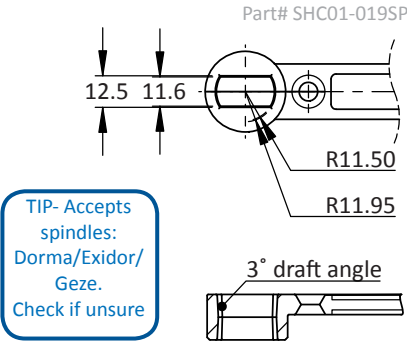

## Floor Spring Layout with ALU60

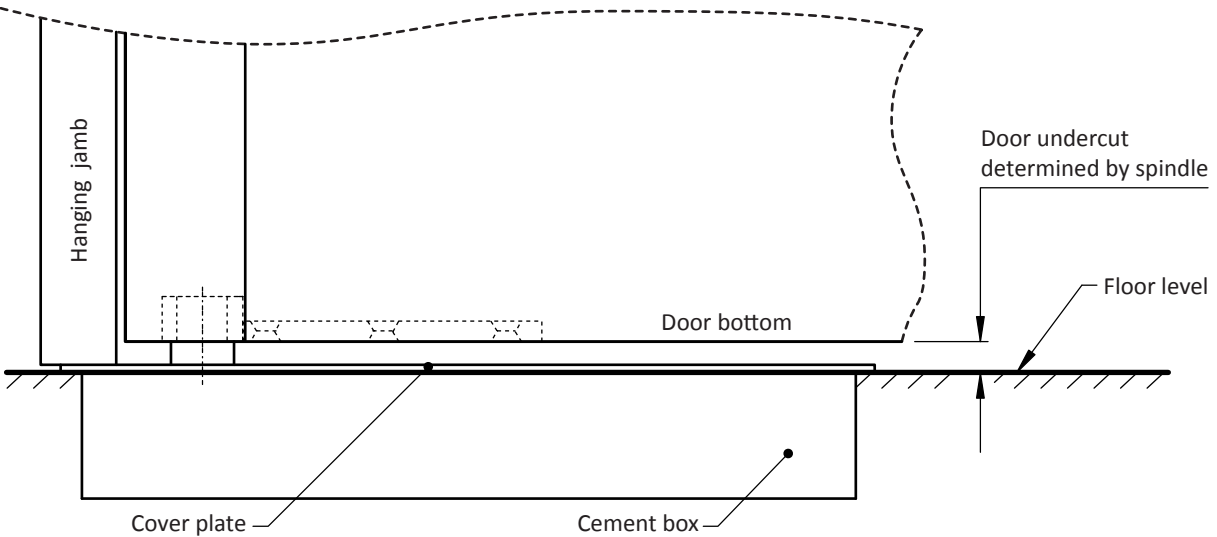
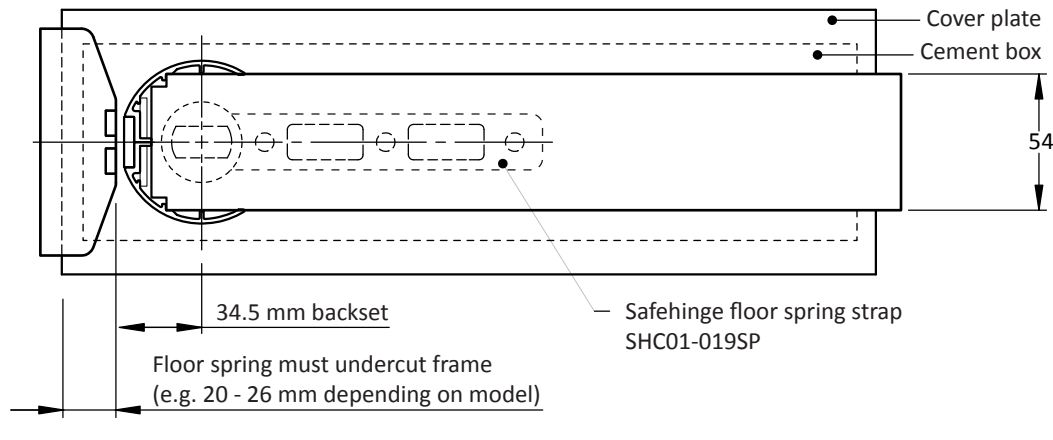

## Floor Pivot Positioning (54 mm doors)

Care should be taken to position components correctly as these will influence the finger safe gap between the door and the frame.

### Floor Plate (ALU60-100 kits)

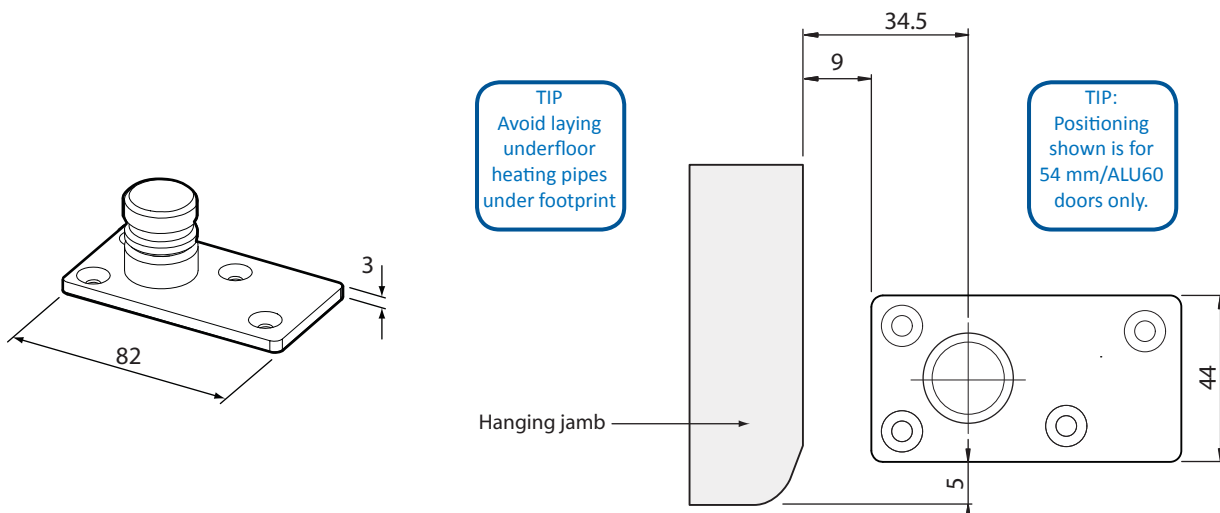

### L-Bracket for 54 mm doors (ALU60-150 kits)

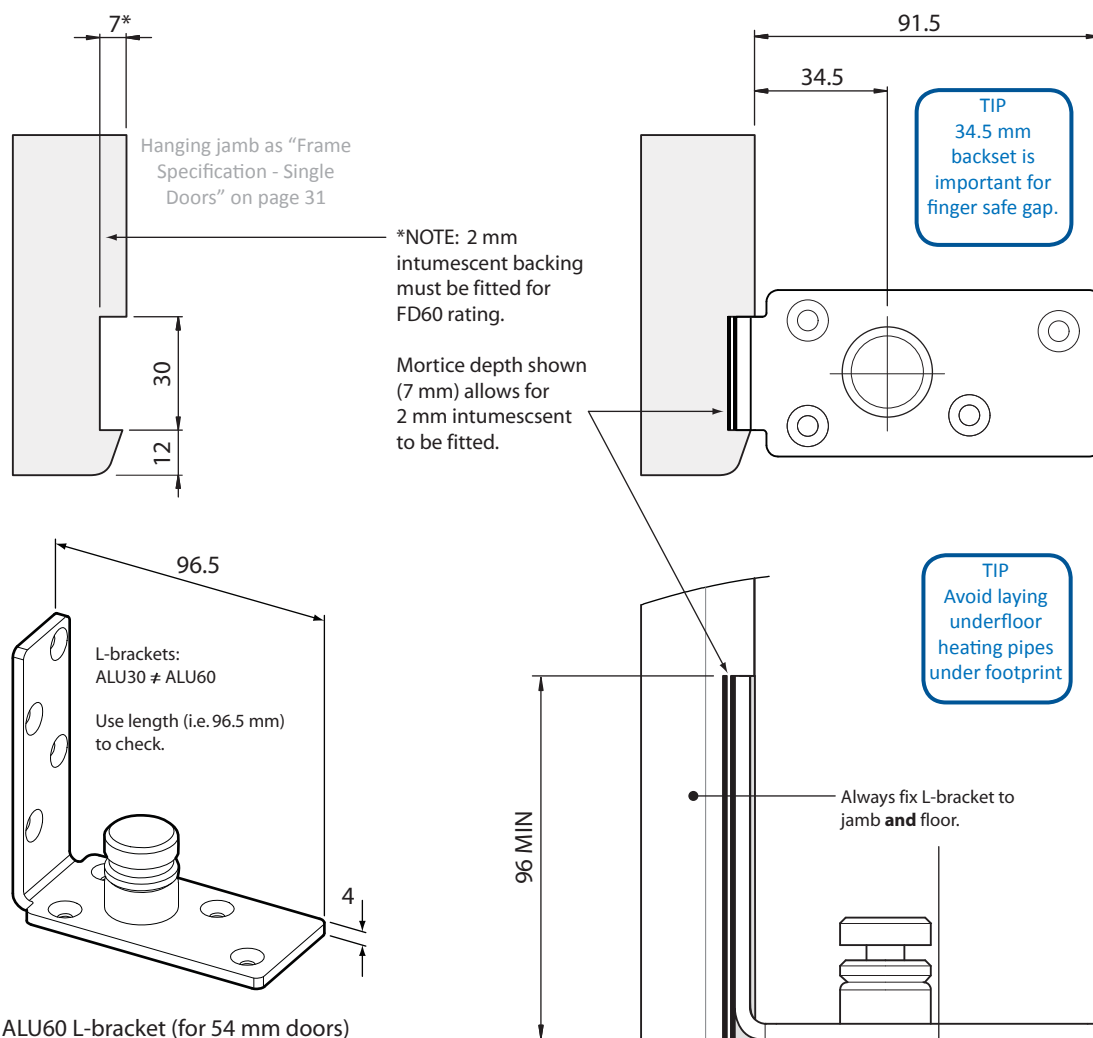

See "Undercuts & Floor Pivot Adjustment" on page 39 for details of flooring build up.

# ALU60 Acoustic Seal Option Drawings

PLEASE NOTE: This page only shows the placement of ALU60 **acoustic** seals which are **additional** to the combined intumescent smoke seals (A - F), detailed under “Lorient Polyproducts - ALU60 Seal Specification” on page 19 or “Intumescent Seals Ltd - ALU60 Seal Specification” on page 22.

## Acoustic Ratings

		dB Reduction	
		Threshold Option 1	Threshold Option 2
		Lorient IS1511	Lorient 8091si
Door core	Blankfort 60 (glazed)	38	37
	Blankfort 60 (unglazed)	36	35
	Halspan (glazed)	36	35
	Halspan (unglazed)	34	33

Table 9

Glazed tests conducted with 23 mm Pilkington Pyrostop. Other types of glass can offer comparable performance - please refer to glass manufacturer data.

## Hanging Jamb

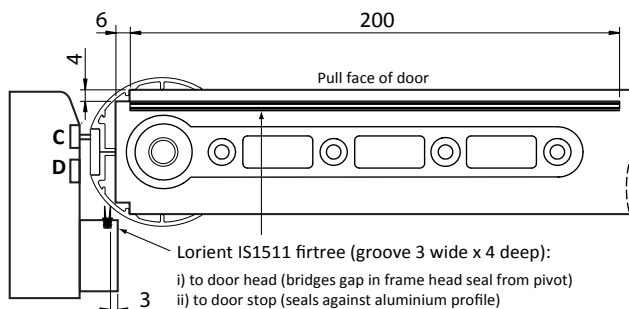

## Frame Head

## Closing Jamb

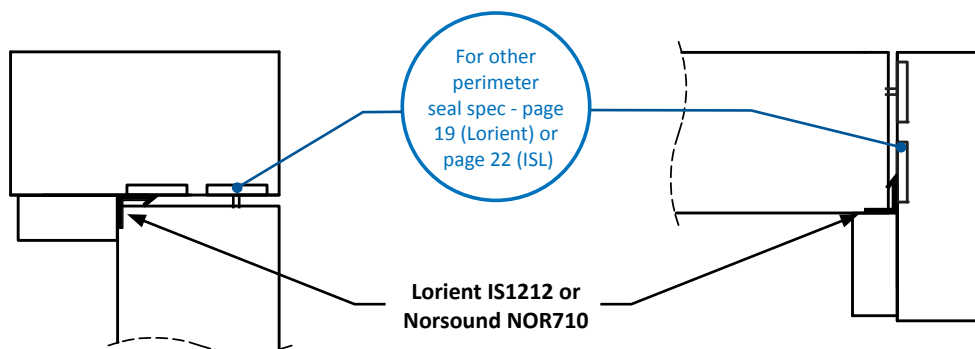

## Threshold Option 1

Lorient IS1511  
6mm firtree

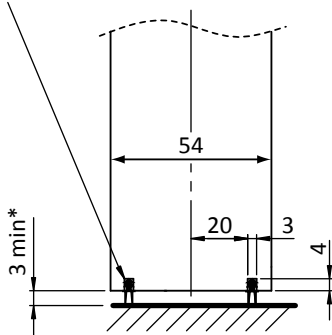

\*if greater than 3mm, recommend compatible raised threshold plate

## Threshold Option 2

Lorient IS8090si  
face-fixed drop seal

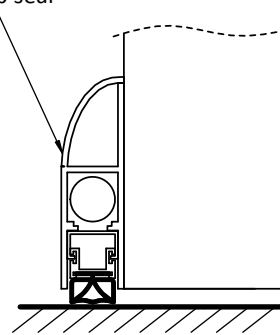

To enable the face-mounted seal to actuate on door stop/frame, recommend a check is made in ALU60 aluminium hanging edge profile and seal cut to length to sit between stops/jambs. Leave a clearance gap on the closing side as per the seal manufacturer's instructions.

# Shared Details: ALU30 & ALU60

## Fitting Components

### 1. Fitting the Top Centre Pivot

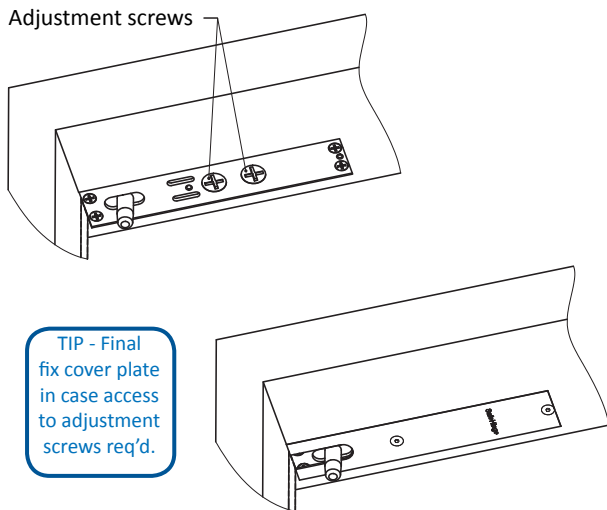
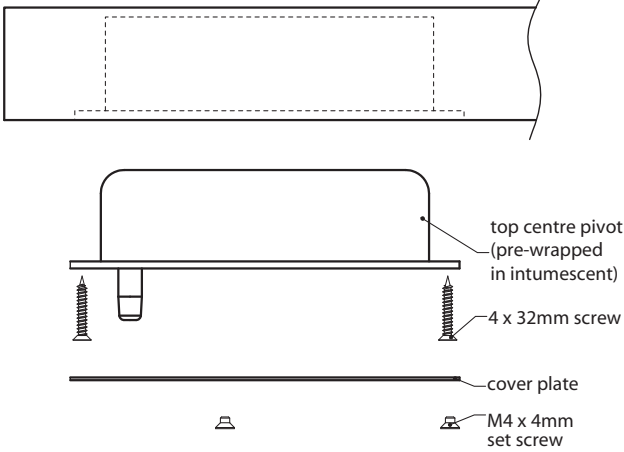

i) Ensure the intumescent wrap is inserted into the mortice or present around the top centre pivot mechanism.

ii) Use supplied 4No. 4 mm x 32 mm screws to fit the top centre to the frame.

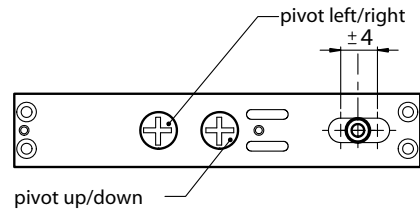

iii) Use supplied 2No. M4 x 4 mm set screws to fit the cover plate.

### 2. Fitting the Aluminium Edge Profiles

#### ALU30

Intumescent supplied loose. Fit for FD30 rating.

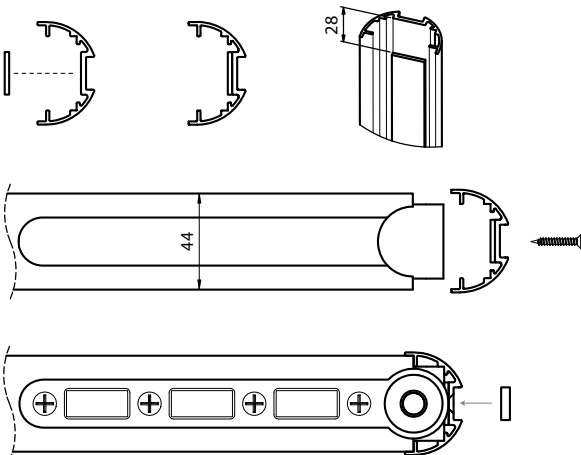

#### ALU60

Intumescent behind profile comes pre-fitted as standard

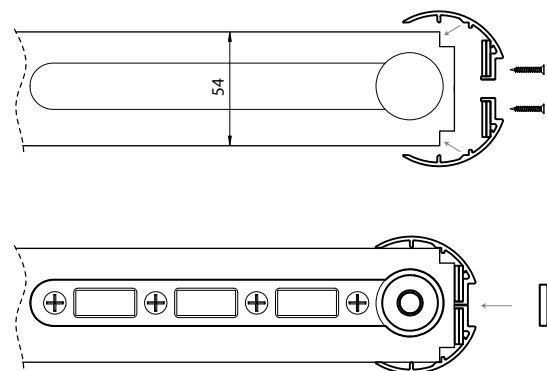

# Undercuts & Floor Pivot Adjustment

The flooring configurations shown in the following section should be regarded as illustrative only. The exact design and configuration of flooring is not the responsibility of Safehinge Ltd.

## Standard Undercut

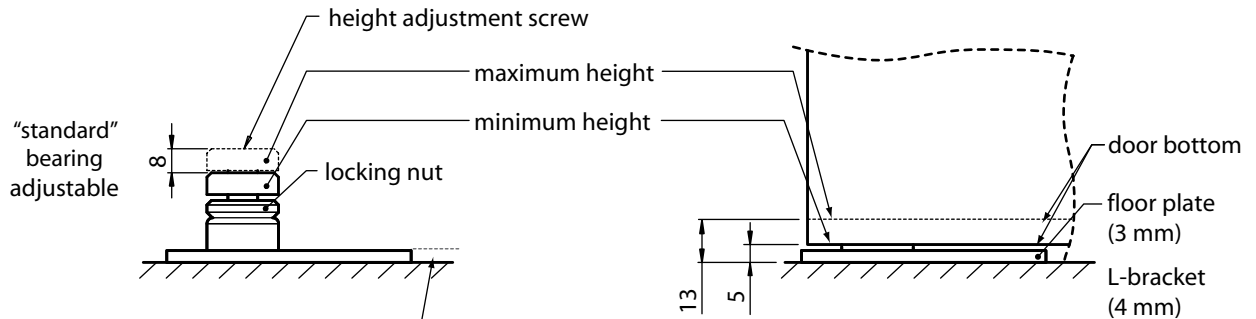

The "standard" bearing is supplied with all regular Safehinge kits.

## Large Undercut Option A

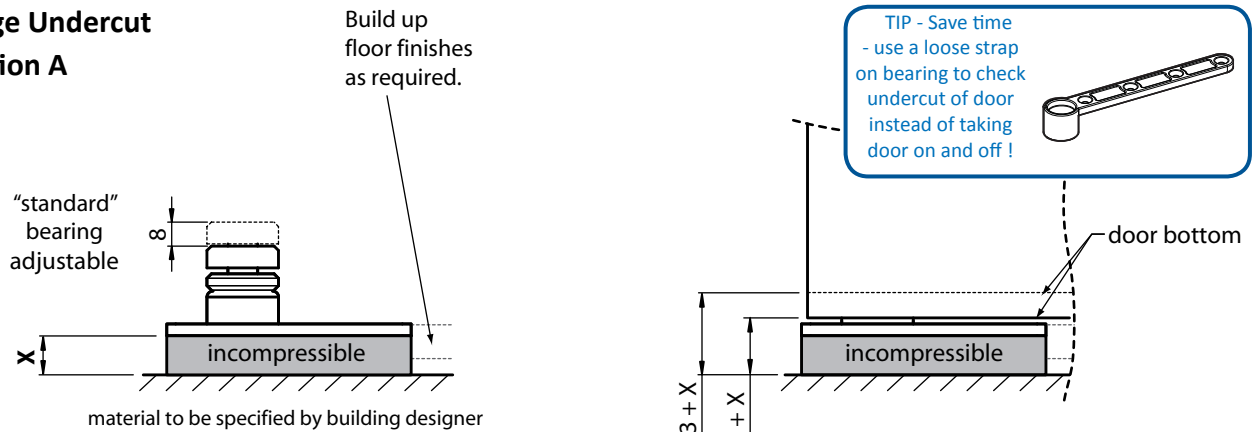

The "standard" bearing is supplied with all regular Safehinge kits.

## Large Undercut Option B

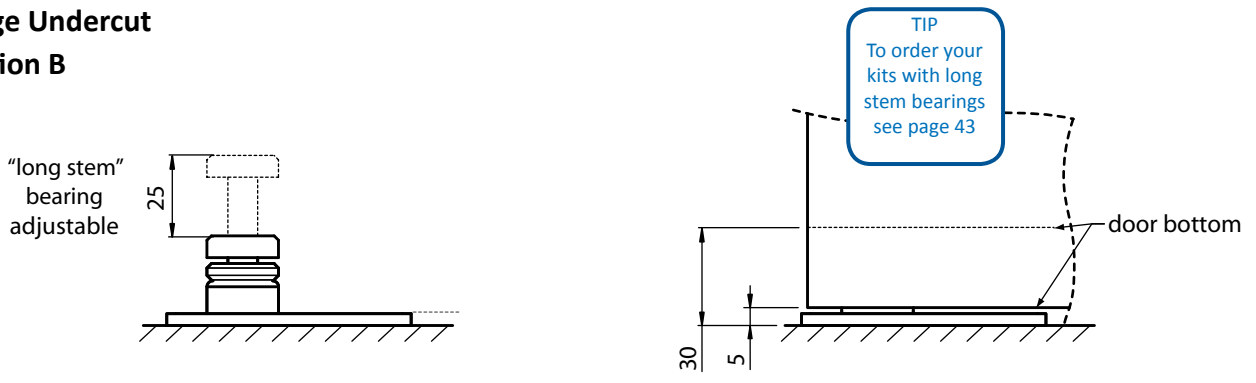

## Sizing Door Stops to Perfection

The hanging side stop is not always the same width as the head stop because of the important finger-safe 2-3mm gap between aluminium profile and stop.

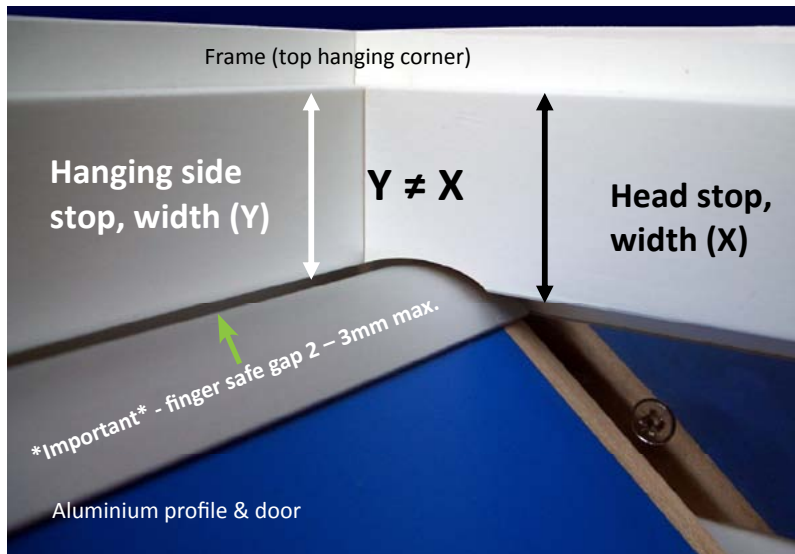

### Helpful gap check!



50 pence coin DOES fit



1 pound coin DOES NOT fit

### ALU30 (44 mm) Hanging Side Stop

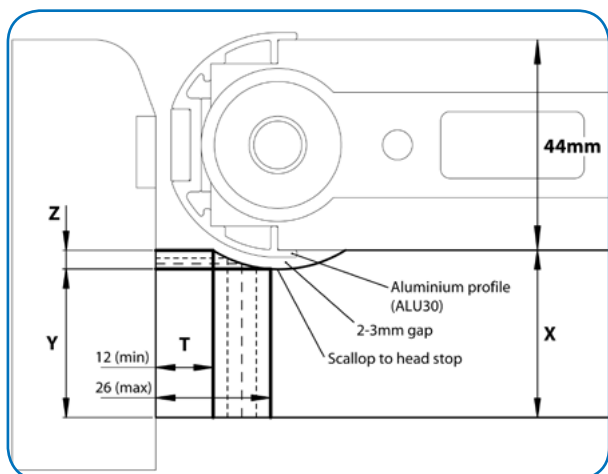

$$Y = X - Z$$

T (mm) stop thickness	Z (mm)
12	0
15	2
18	3
21	4
26 (max for hanging stop)	4

**Example:** If head stop is 35x15 mm, then

X = 35 mm T = 15 mm.

Z = 2 mm (taken from table)

$$Y = X - Z$$

$$Y = 35 - 2 = 33 \text{ mm}$$

**TIP**  
Use pinned door stops. These can be moved if req'd.

### ALU60 (54 mm) Hanging Side Stop

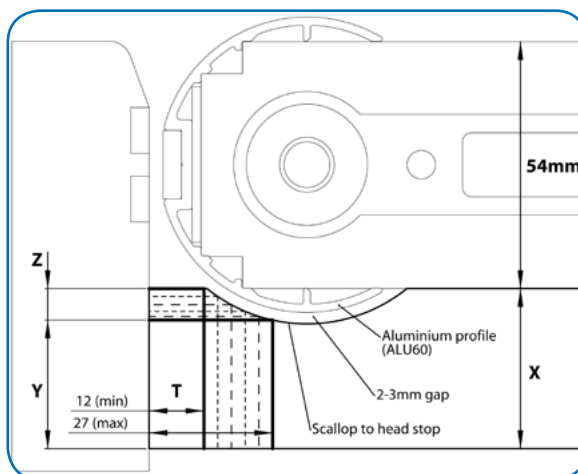

$$Y = X - Z$$

T (mm) stop thickness	Z (mm)
12	0
15	2
18	3
21	5
24	6
27 (max for hanging stop)	7

**Example:** If head stop is 40x18 mm, then

X = 40 mm T = 18 mm.

Z = 3 mm (taken from table)

$$Y = X - Z$$

$$Y = 40 - 3 = 37 \text{ mm}$$

## Opening Angle Limit

All pivot doors - whether Safehinge ALU or not - have a maximum opening angle beyond which they will “bind” on the door frame. It is strongly recommend that measures are taken to prevent binding from occurring.

**Recommended stop angle: 100°**

(Maximum opening angle: 110°)

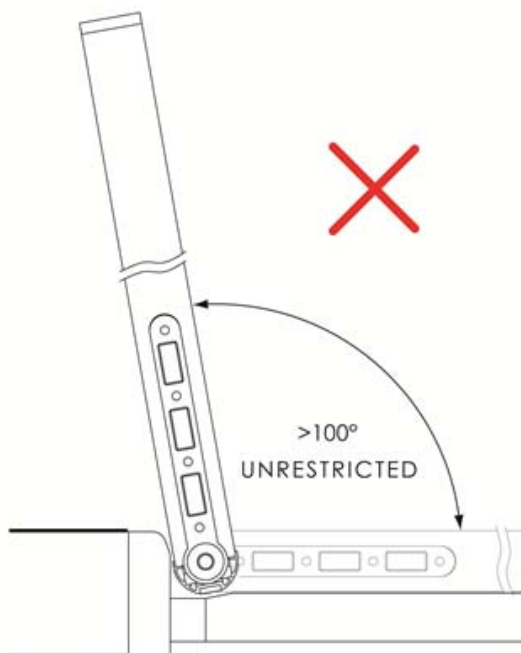
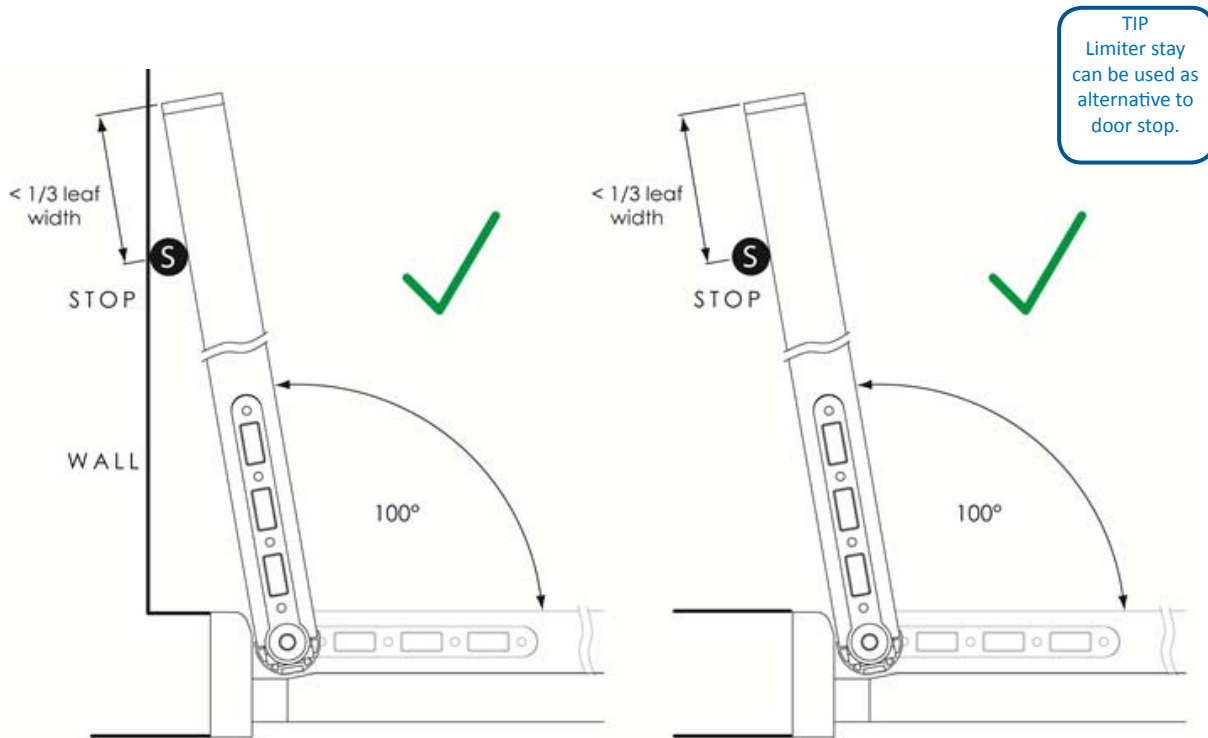

**WARNING** - Door binding on frame exerts extreme force on door, frame and ironmongery and may lead to damage/failure.

Door closer with back check improves situation, but should not be used in place of door stop or limiter stay.

## Installation Instructions

### Step 1 - Install Frame

Install the frame assembly into the structural opening. For fire, smoke and acoustic doors, pack the gap between the door assembly and the wall in accordance with BS8214:2008 and ASDMA Best Practice Guide to Timber Fire Doors. Take particular care to ensure hanging jamb is set straight as this will influence the finger-safe gap between the door and the frame.

### Step 2 - Positioning of Bottom Pivot

Position the bottom pivot (floor plate or L-bracket) as directed on page 29 (ALU30) or page 36 (ALU60).

Use the supplied screws and plugs to fix the bottom pivot in position. Always fix the L-bracket to both floor and frame.

**IMPORTANT:** Care should be taken to position correctly as this will influence the finger-safe gap between the door and the frame.

Recommended to rebate the bottom pivot into the floor to eliminate a minor trip hazard.

### Step 3 – Height Adjustment of Bottom Pivot

Determine the desired gap at the threshold and then set the height of the pivot bearing accordingly.

**IMPORTANT:** Ensure the thread of pivot bearing is securely engaged with the threaded boss bottom pivot. After height adjustment has been made, securely tighten locking nut against thread. This will require a flat head screwdriver and spanner.

### Step 4 – Prepare the Top Centre Pivot

Remove and store the top centre cover plate (if fitted). Check that the pivot pin is fully retracted and central **(not positioned to the Left or Right extremes)**.

**IMPORTANT:** Do not operate the adjustment screws with power tools.

### Step 5 – Hanging the Door

**IMPORTANT:** It is Recommended to follow Health and Safety Executive guidelines when lifting ([www.hse.gov.uk](http://www.hse.gov.uk))

With the door in a 90° open position and tilted slightly, lift the door and carefully locate the bottom strap cup onto the pivot bearing. When this has been located, raise the door to align the retracted top centre pivot pin with the top strap bearing (**NOTE - it can help to mark the pivot centre of strap on the door edge to help align when hanging.**). Extend the pivot pin to locate it in the bearing.

**IMPORTANT:** Ensure the pin is fully extended and securely located in the top strap bearing (this requires approximately eight full turns of the “retract/extend” adjustment screw). Additionally, on the top centre adjustment ruler, look for the markers - these should be visible when the pin is fully down.

If required, a half turn in the “retract” direction (after fully extending) can ease the “hanging edge gap” adjustment screw.

### Step 6 – Check Threshold Gap

Check the gap at the threshold hanging side is as required. If height adjustment is necessary, remove the door, adjust the floor plate and then re-hang the door in accordance with Steps 3 – 5.

### Step 7 – Set the Finger-Safe Gap

The finger safe gap (hanging edge) should be 2-3 mm. Adjust the “pivot left/right” adjustment screw on top centre until this dimension is achieved at the top of the door. Check the gap is consistent the full height of the door (test as shown on page 40).

### Step 8 – Check Swing

Check the door is swinging correctly. Check that gap sizes around the perimeter are correct and that there is no excessive rubbing on the hanging side. Make necessary adjustments. Fix the cover plate in position over the top centre pivot when complete.

## Ordering Safehinge ALU Kits

Product coding explained.

### ALU30-1 00-LOR

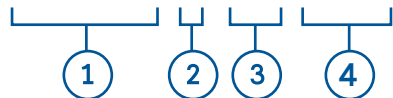

#### 1 Choose kit type

Non-fire rated  
FD30  
up to 32dB

**ALU30-XXX-XXX**

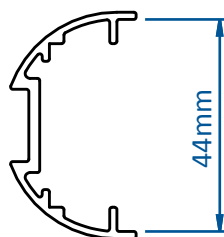

FD60  
up to 38dB\*

**ALU60-XXX-XXX**

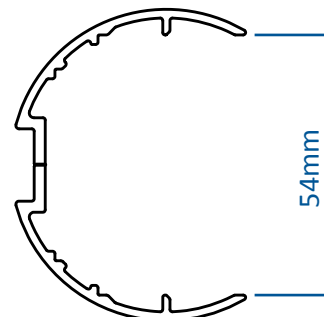

\* glazed - see page 37

#### 2 Choose kit length (door height)

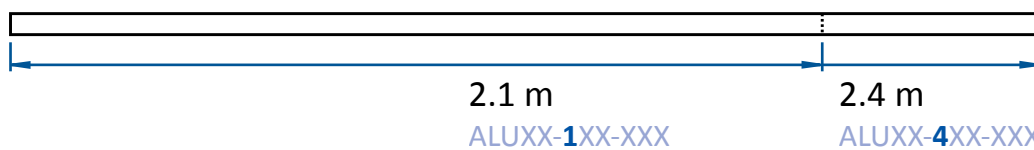

#### 3 Choose bottom pivot

Floor plate

**ALUXX-X00-XXX**  
(standard bearing)

**ALUXX-X00LS-XXX**  
(with long stem bearing)

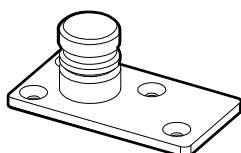

L-bracket

**ALUXX-X50-XXX**  
(standard bearing)

**ALUXX-X50LS-XXX**  
(with long stem bearing)

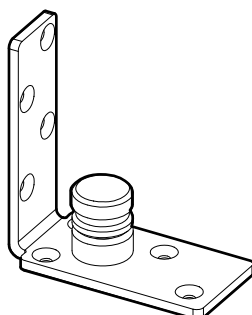

Floor spring (slotted strap)

**ALUXX-X26FS-XXX**

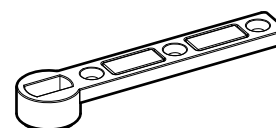

#### 4 Choose intumescent



**ALUXX-XXX-LOR**



**ALUXX-XXX-ISL**